

1.

M1700_03

rauch

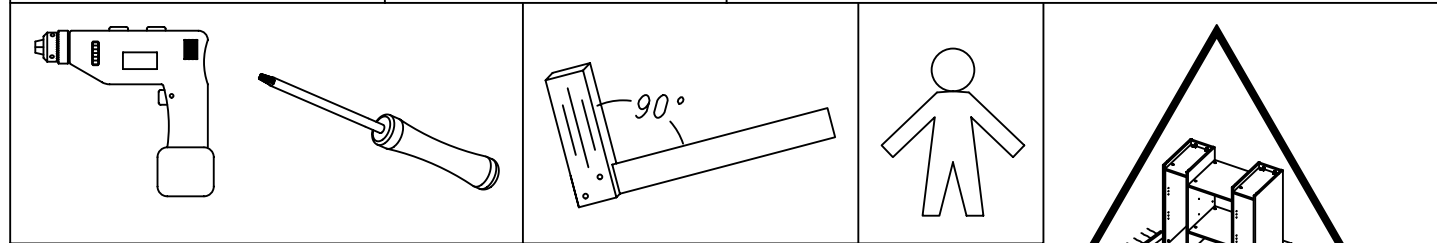
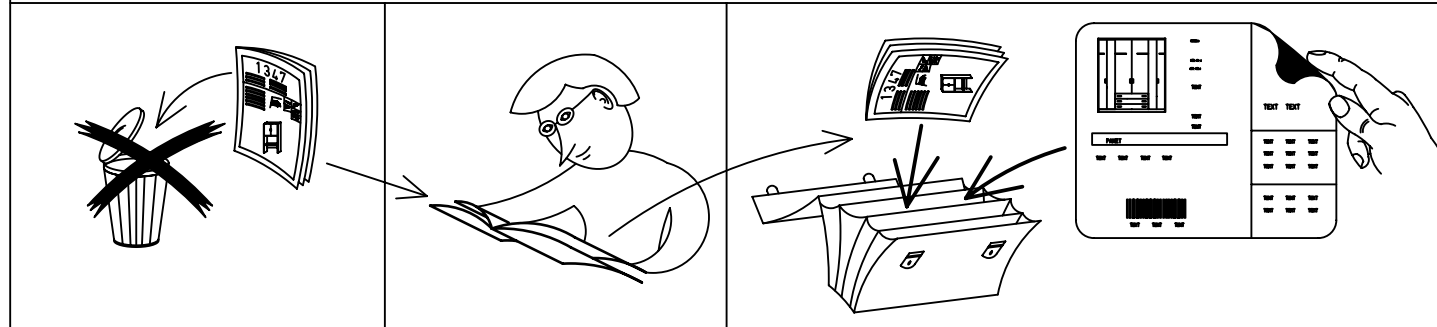

Typ I

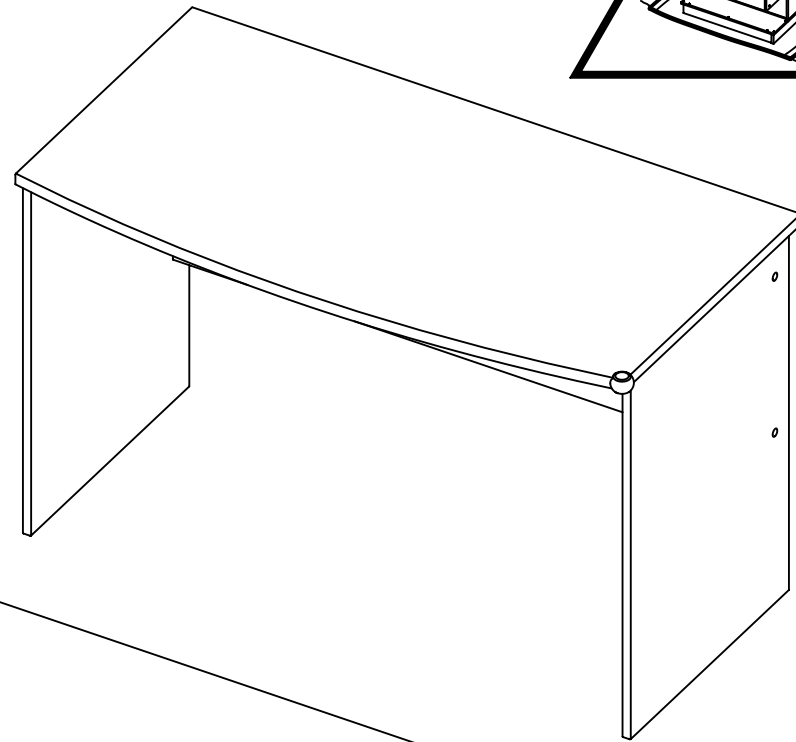

Typ II

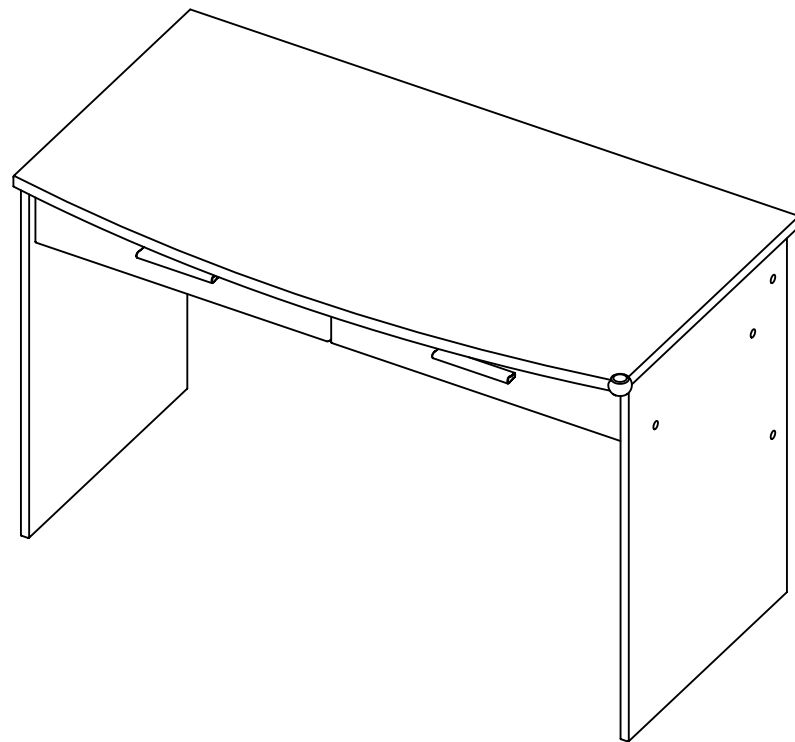

2.

Typ I

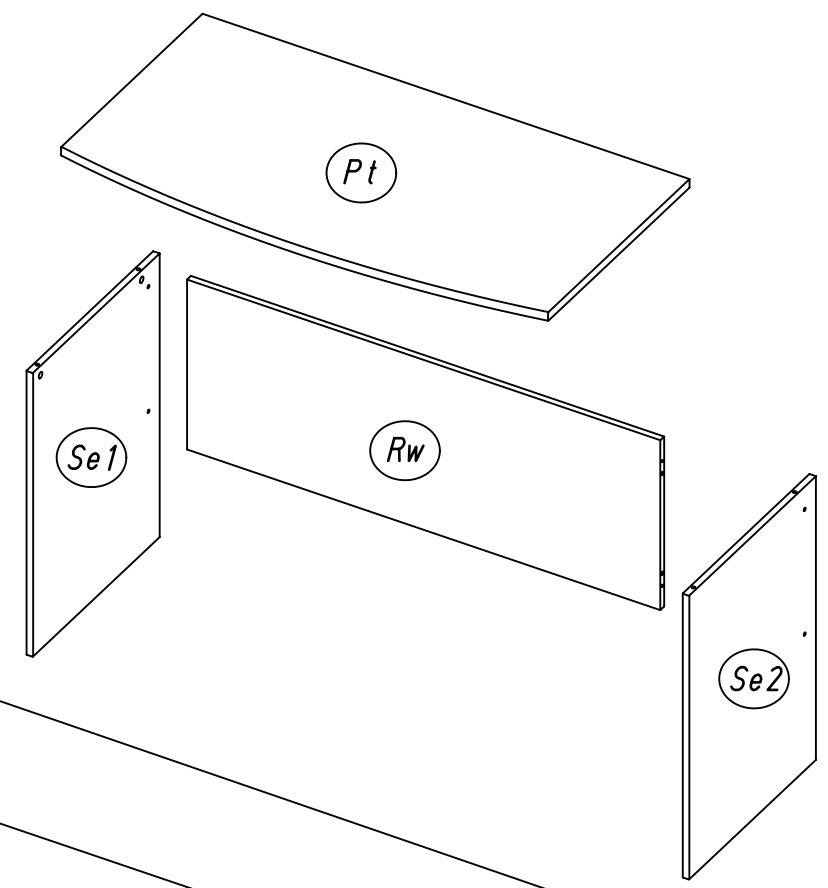

Typ II

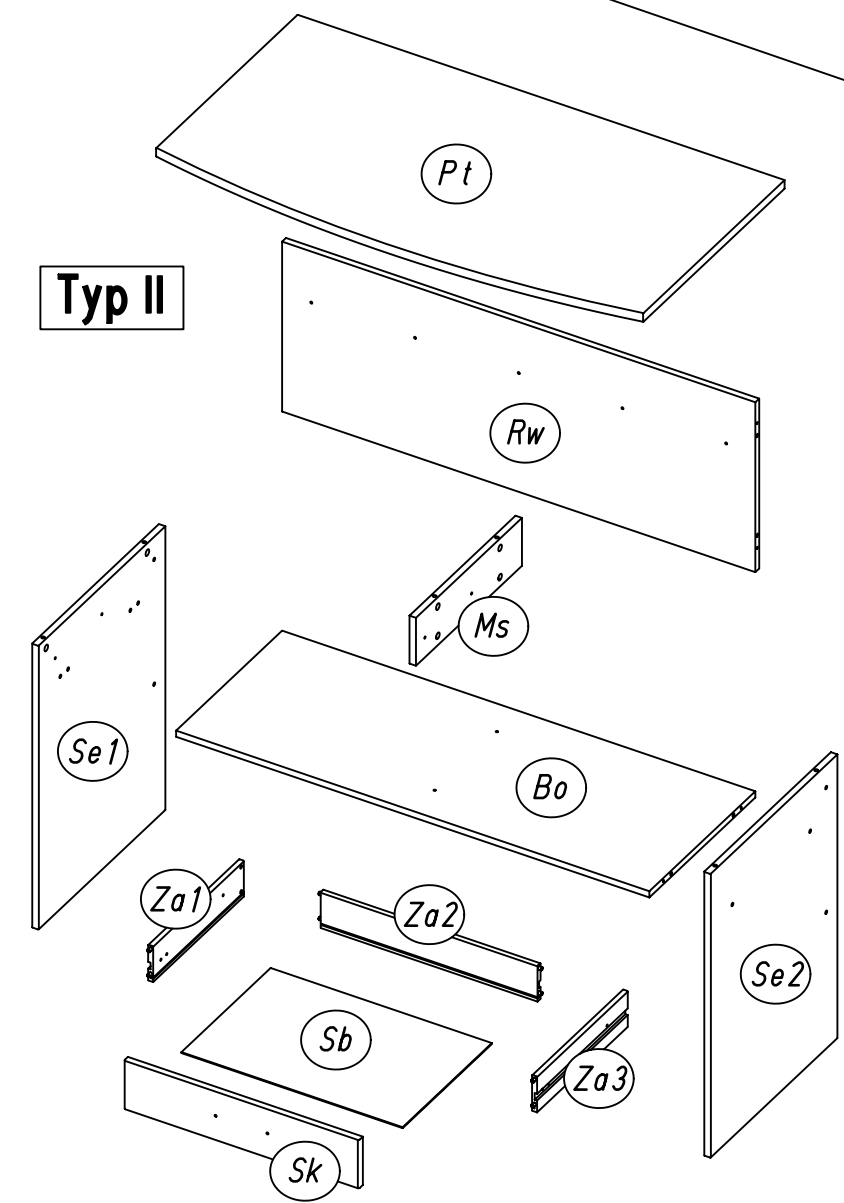

3.

Typ I Typ II

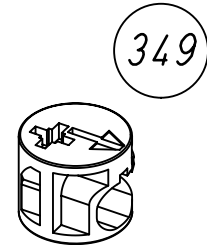
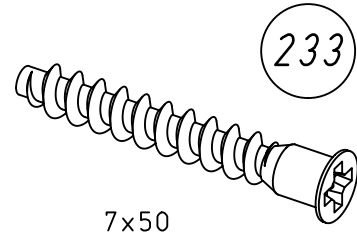
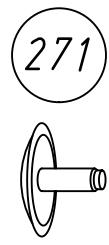
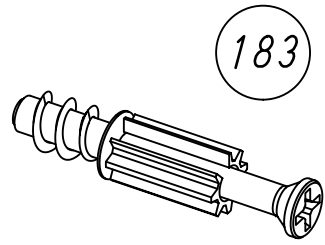

Typ II

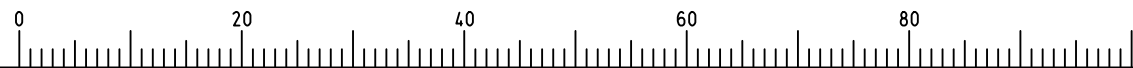
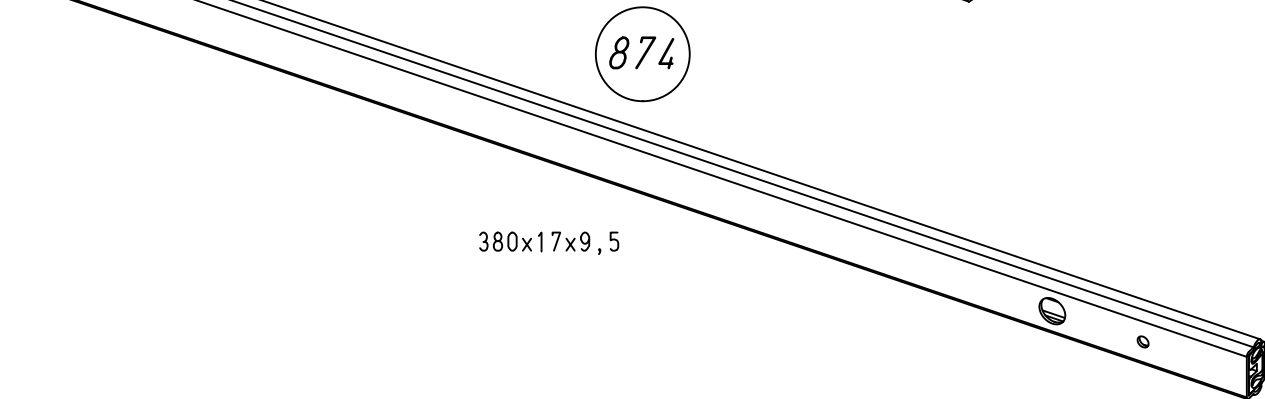
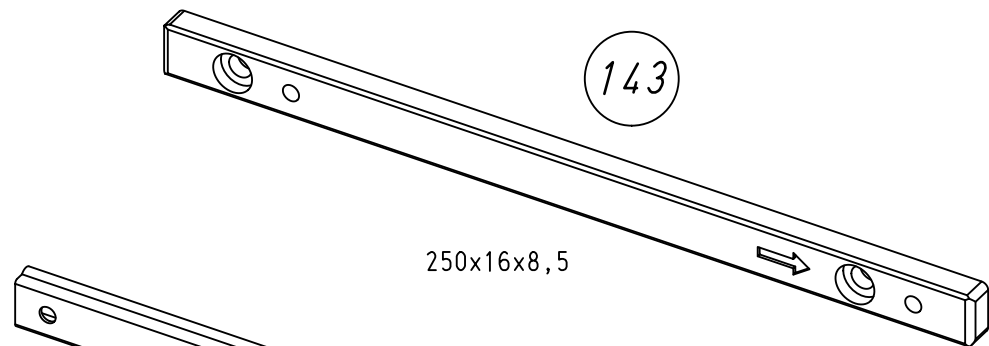
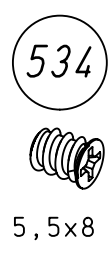
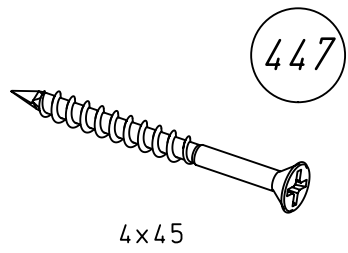
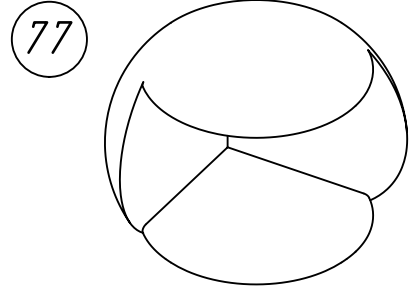
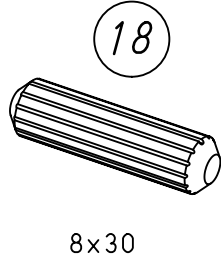
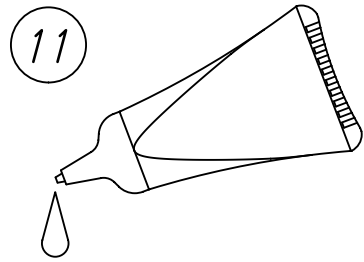

M1700

4.

1 Typ II

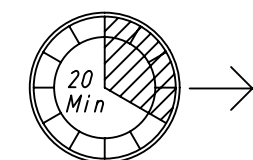
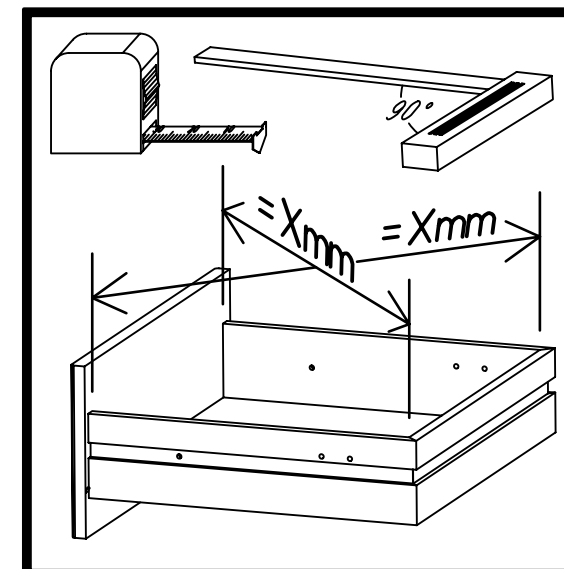
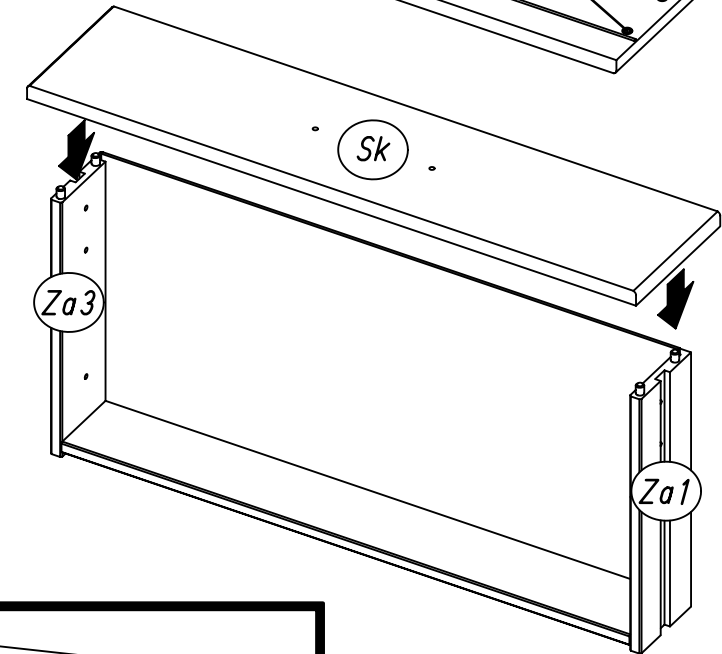
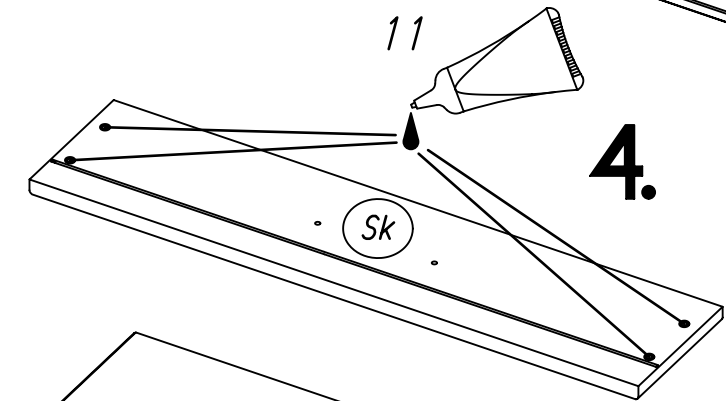
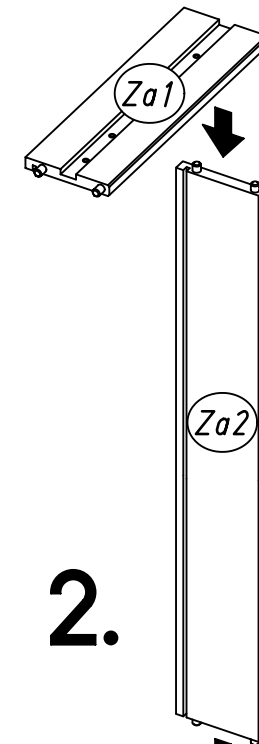
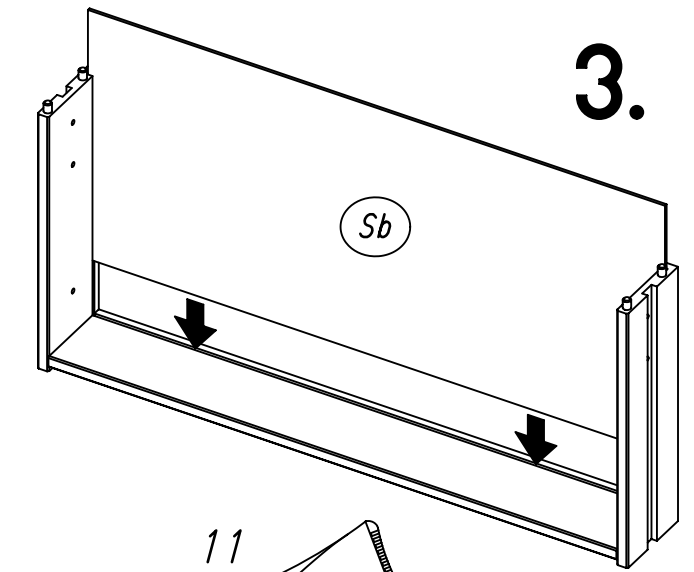
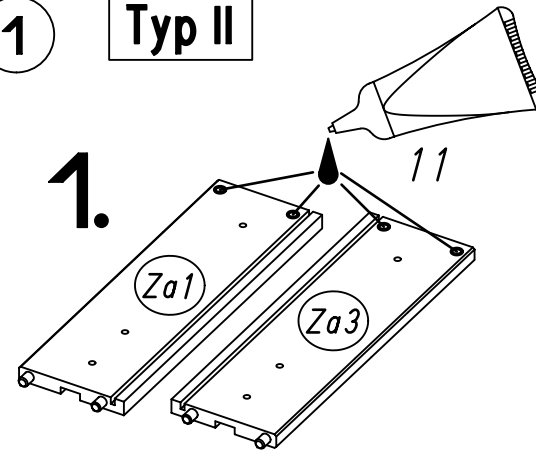

M1700

2 183

Typ I

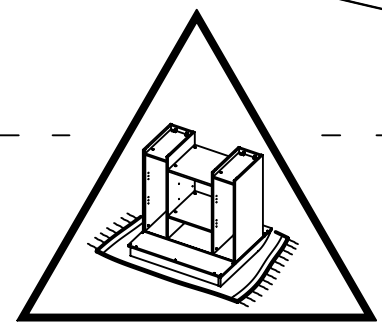
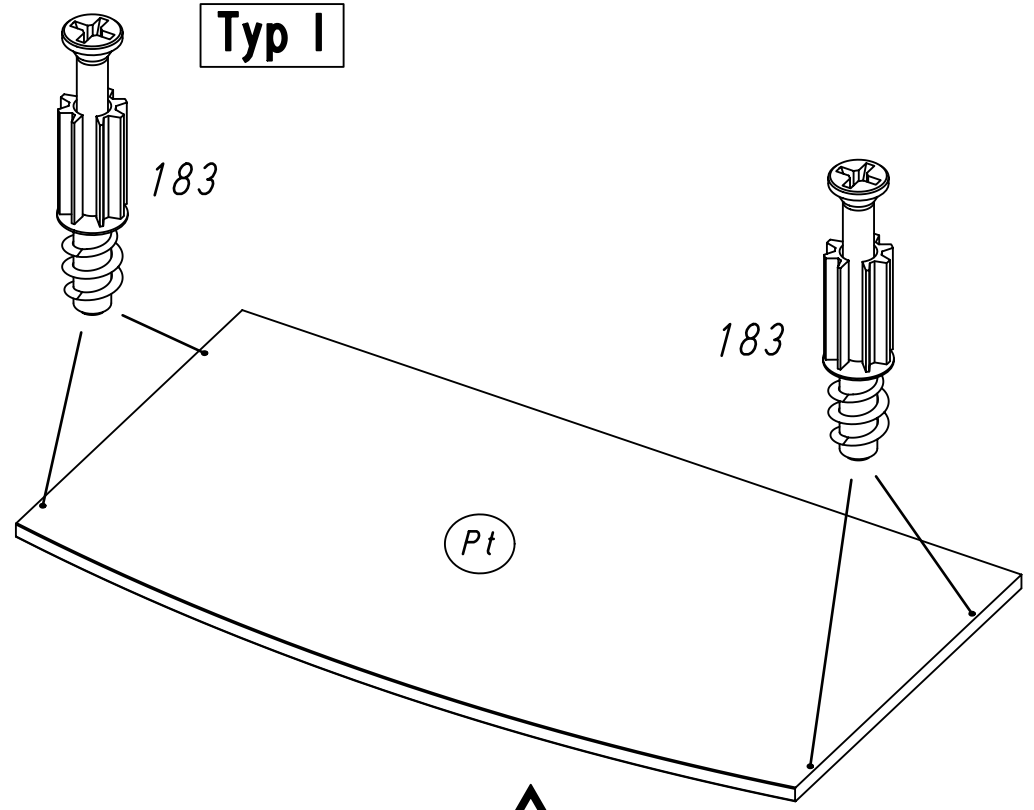

Typ II

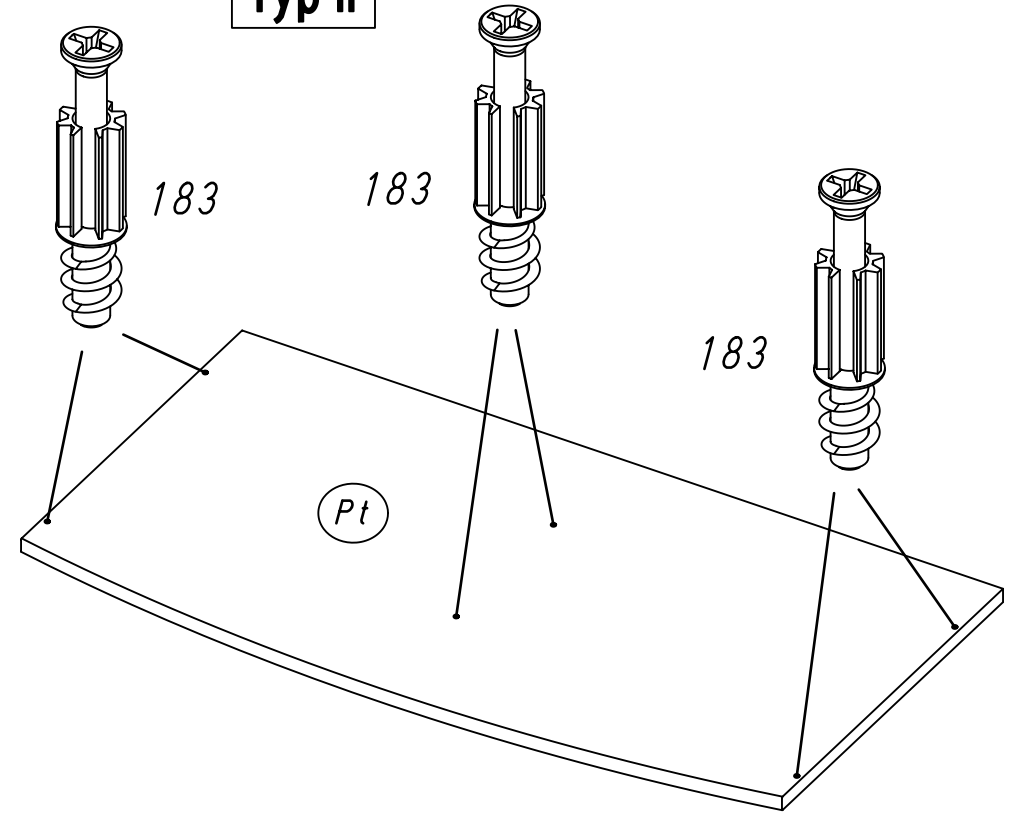

3 349

Typ I Typ II

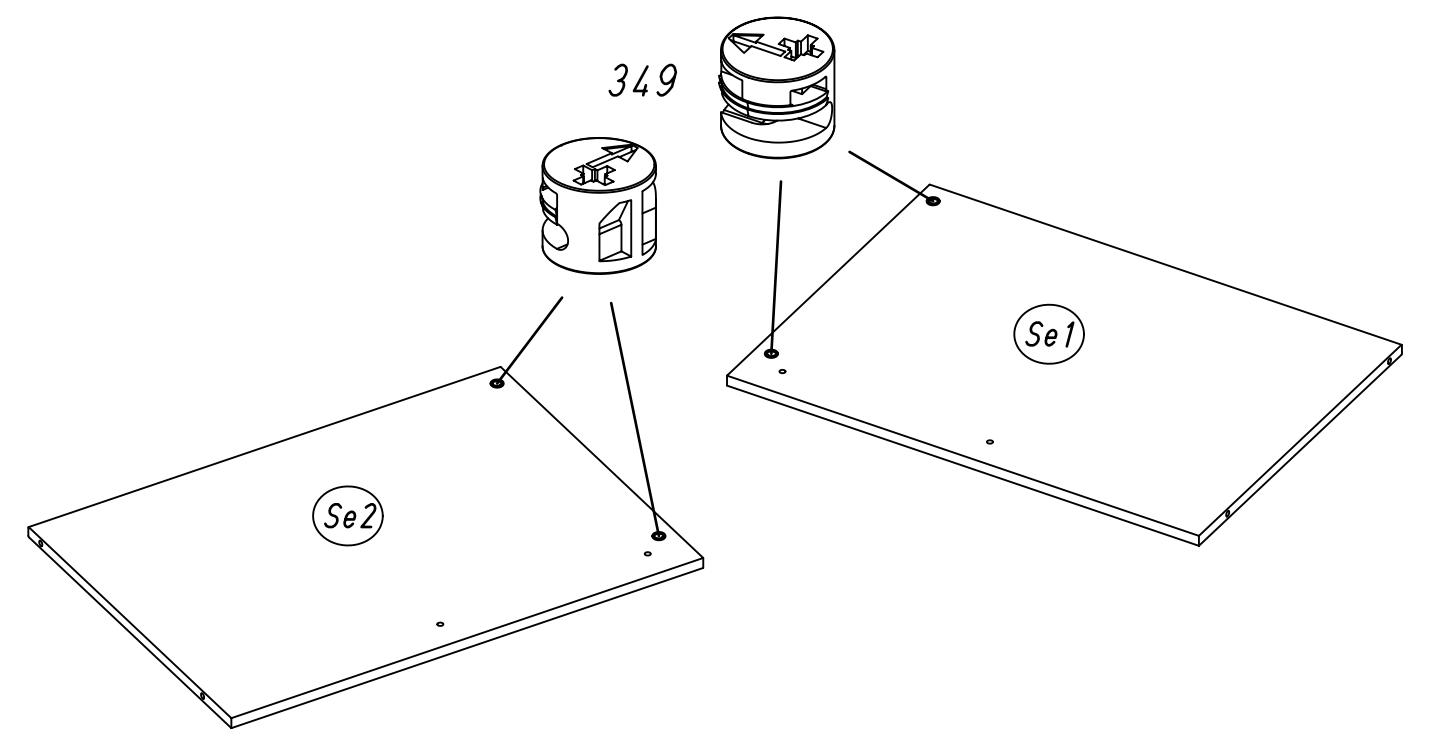

Typ I

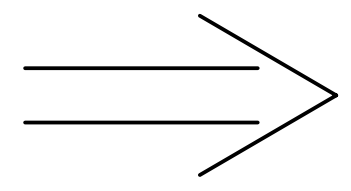

4 143 779

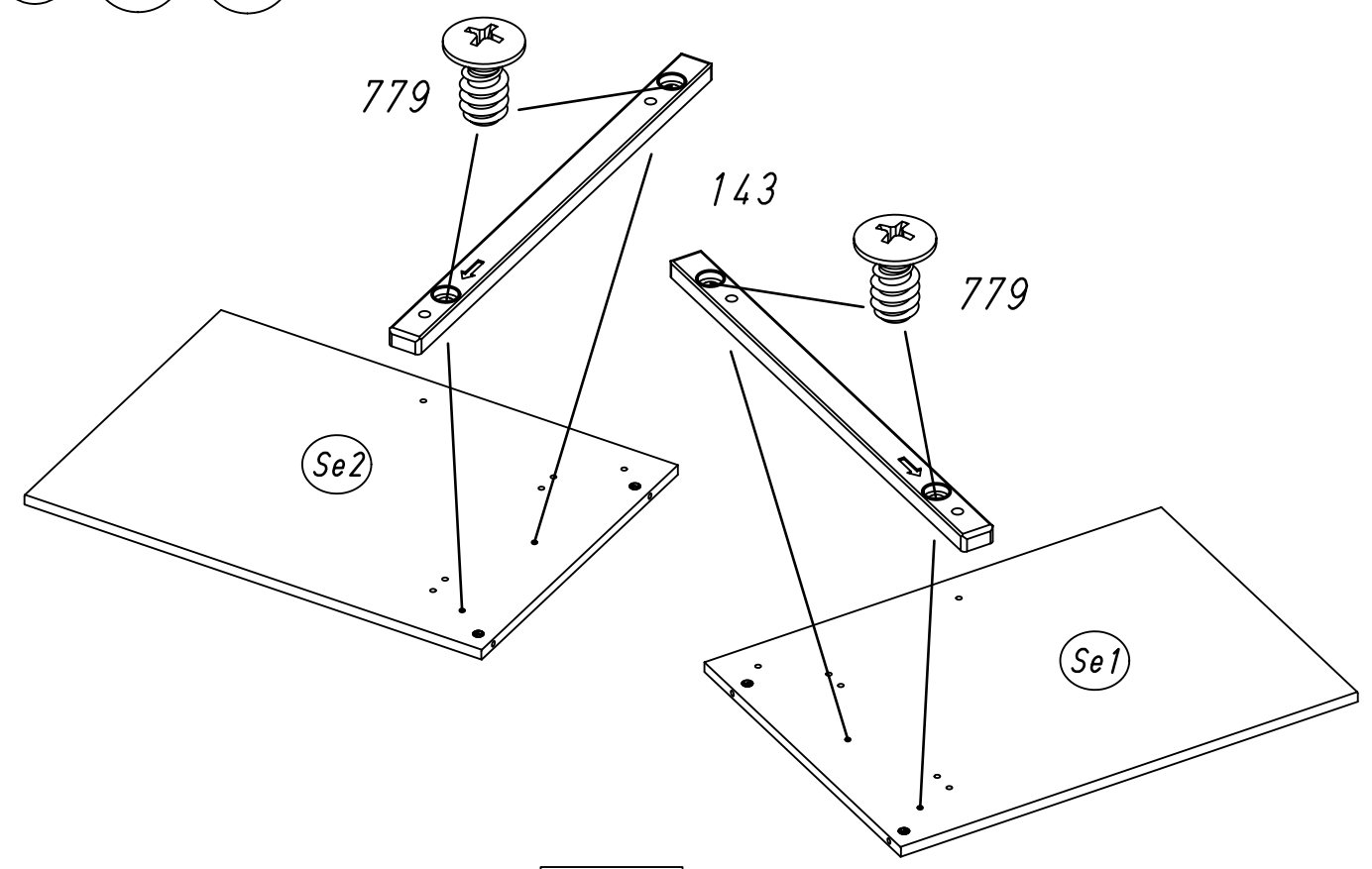

Typ II

5 534 874

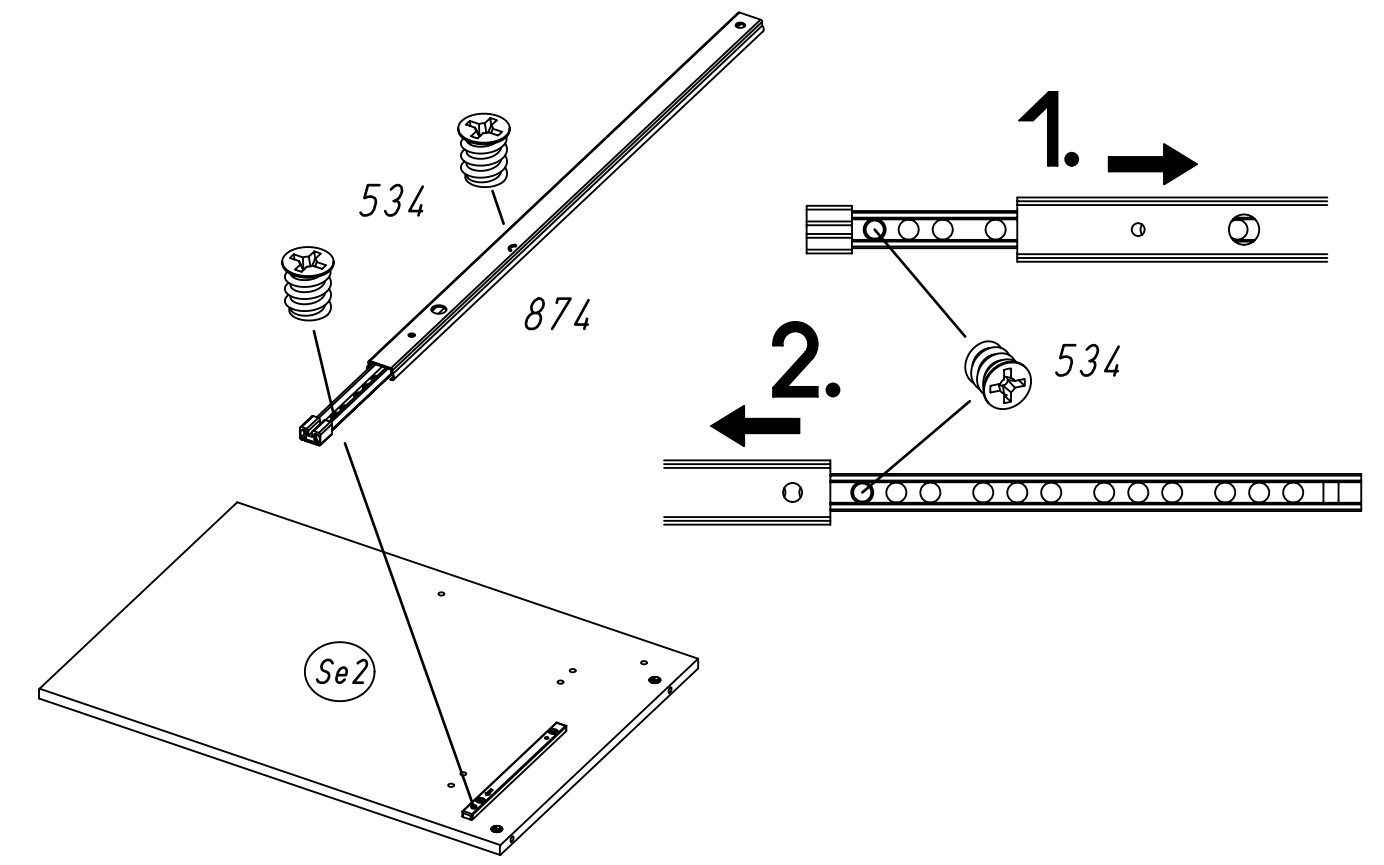

6 534 874

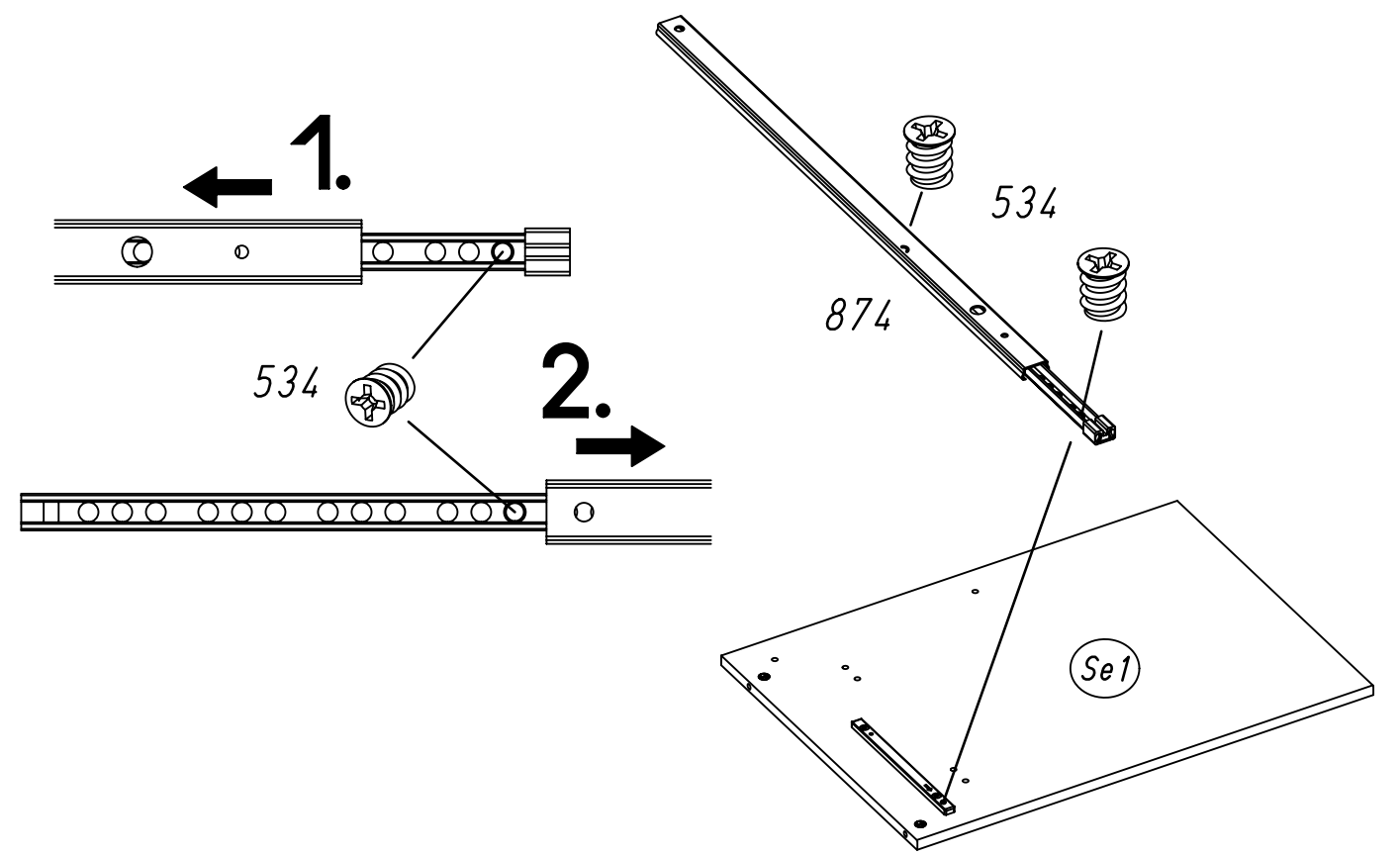

Typ II

7 349

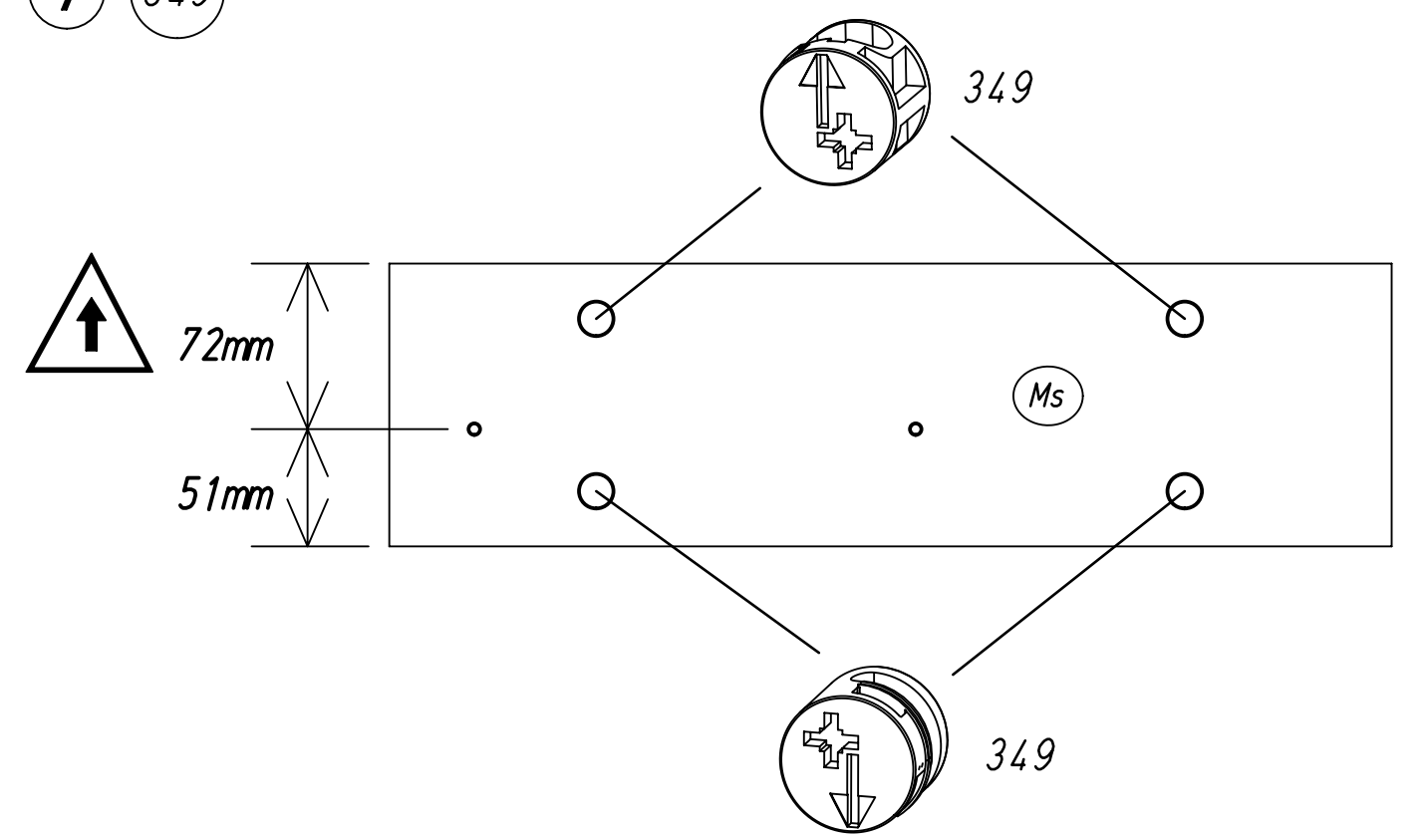

8 534 874

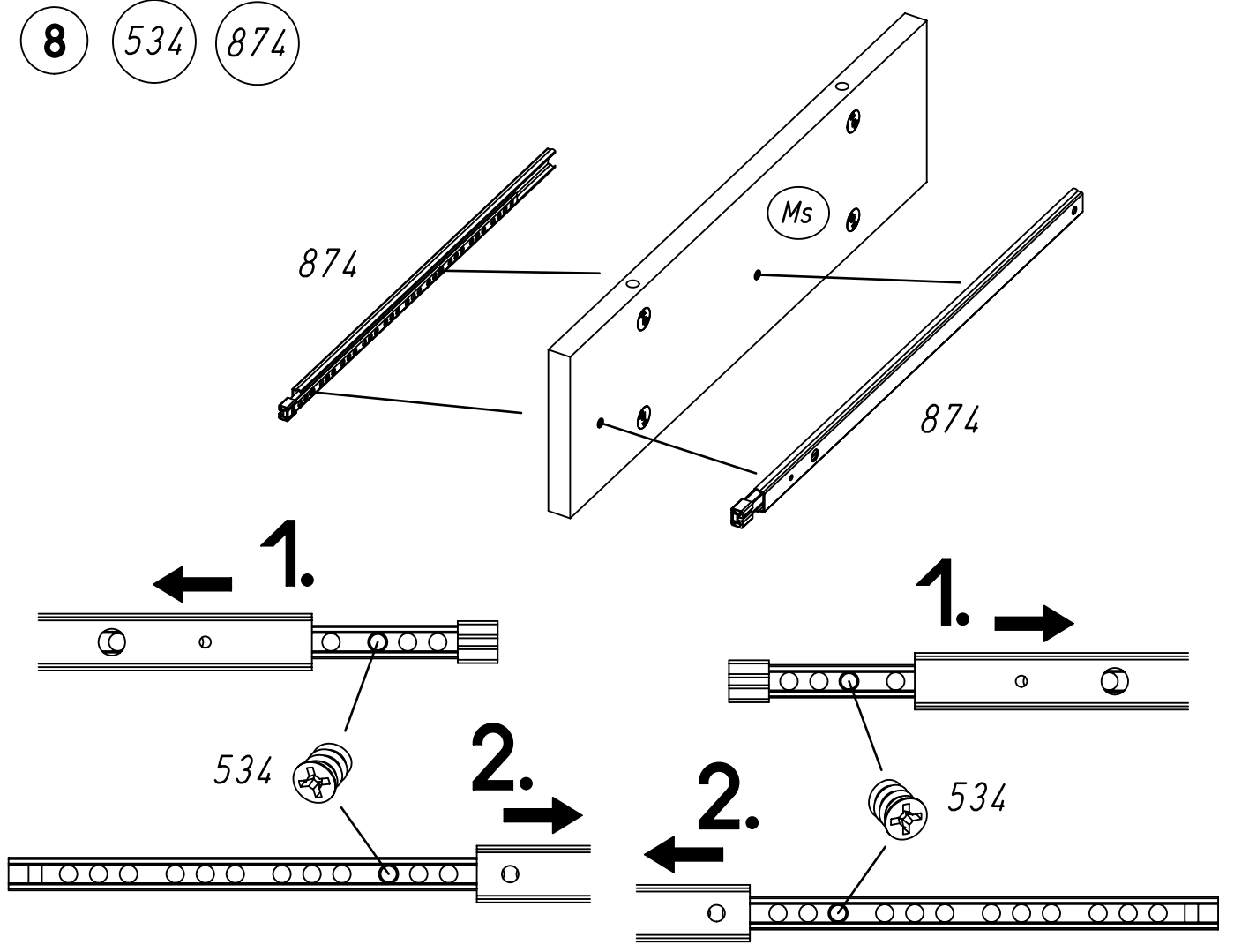

Typ II

9 18 183

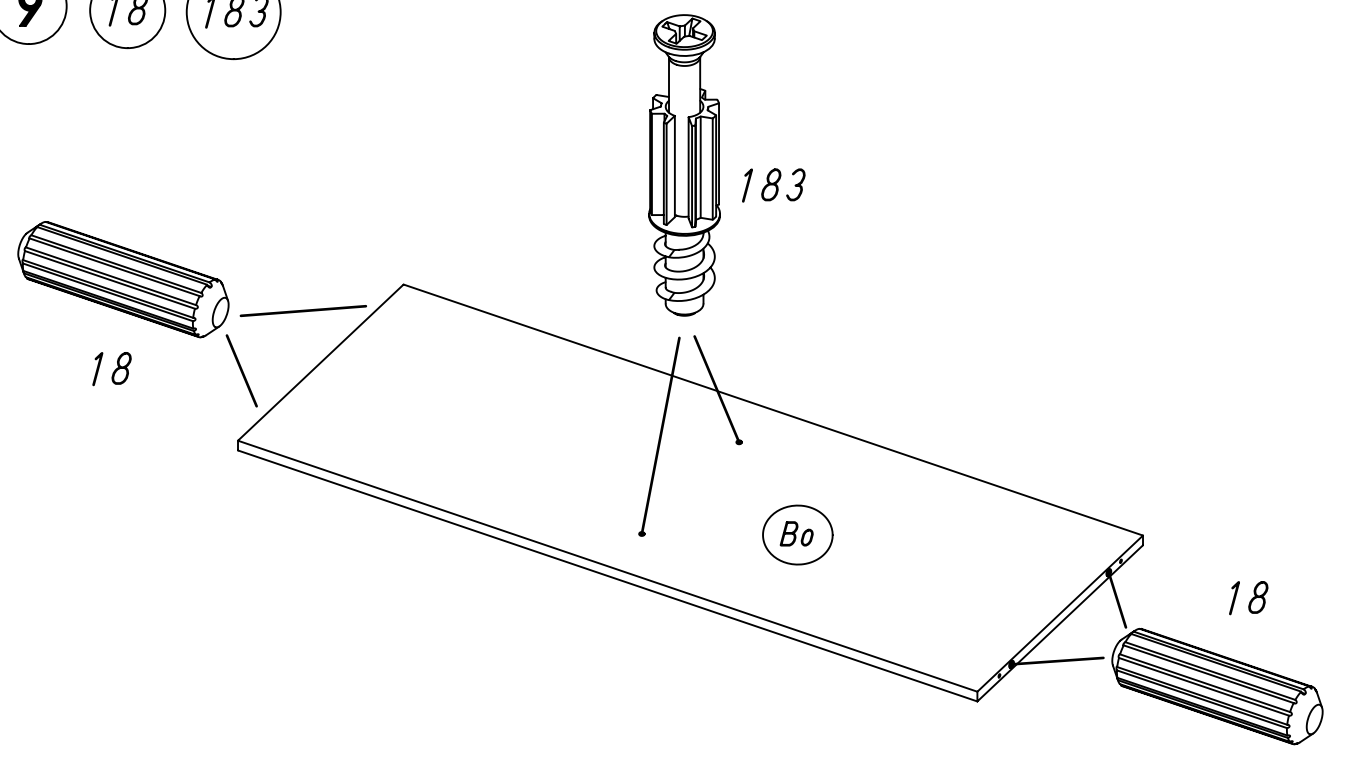

10

Typ I

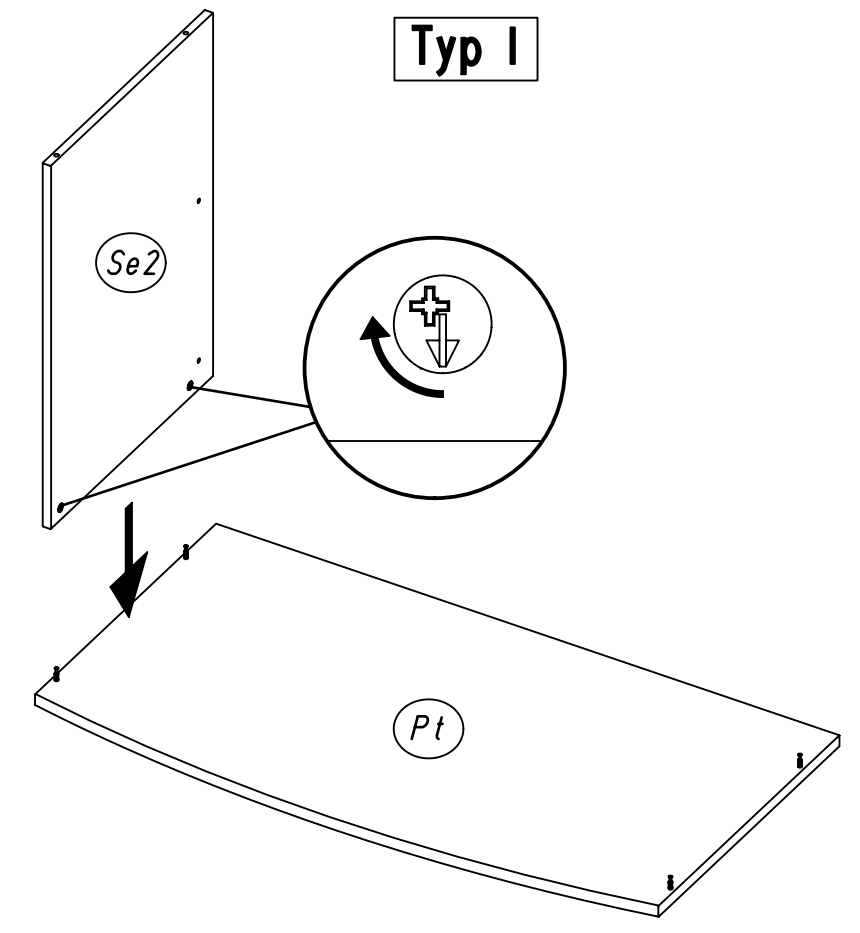

Typ II

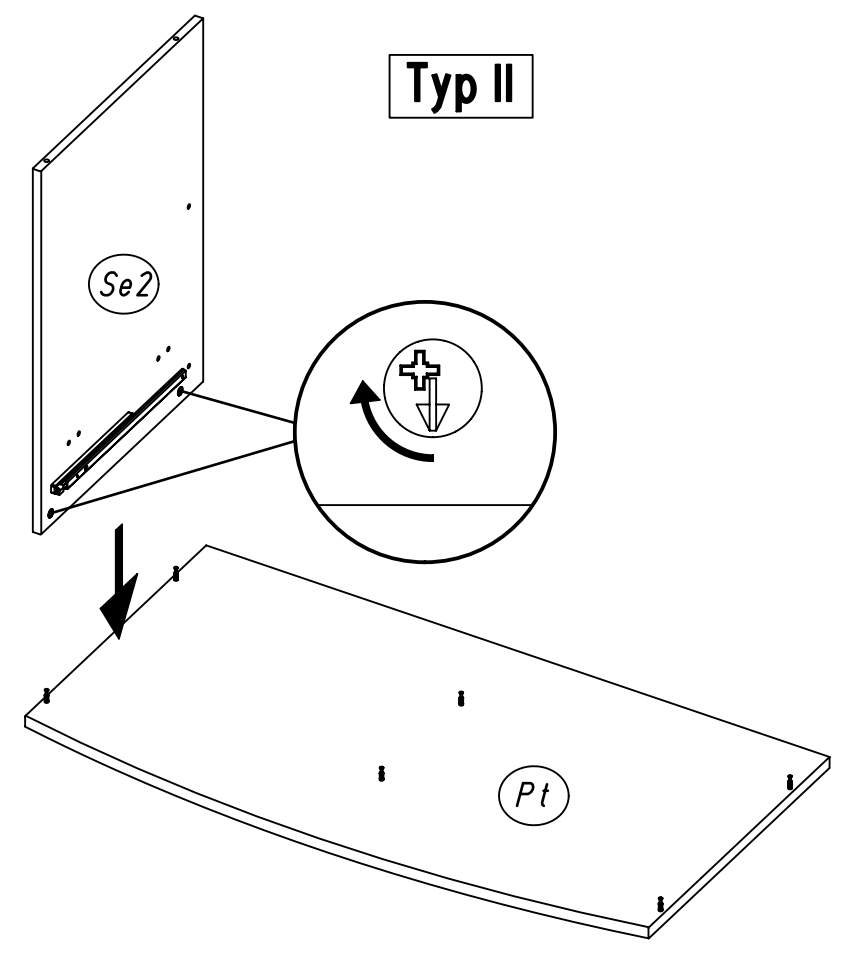

11 233

Typ I Typ II

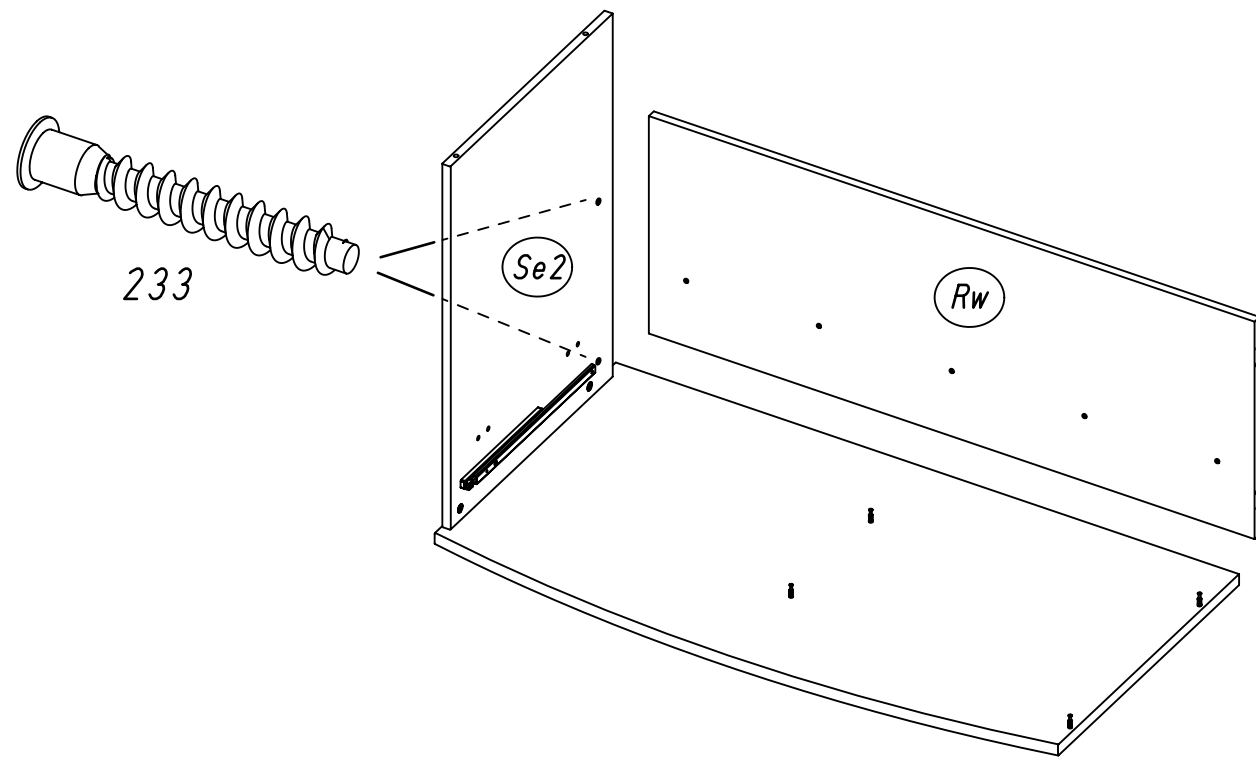

13 233

Typ II

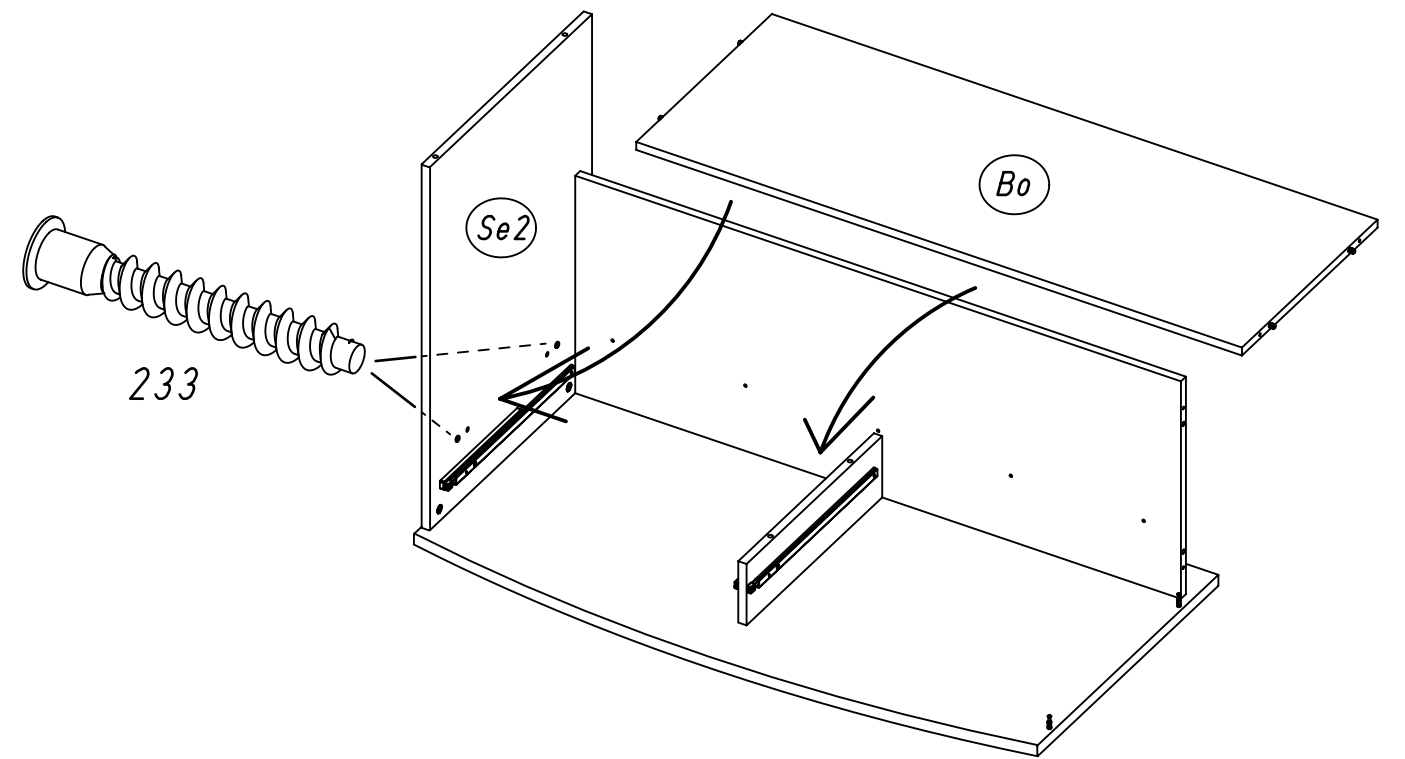

12

Typ II

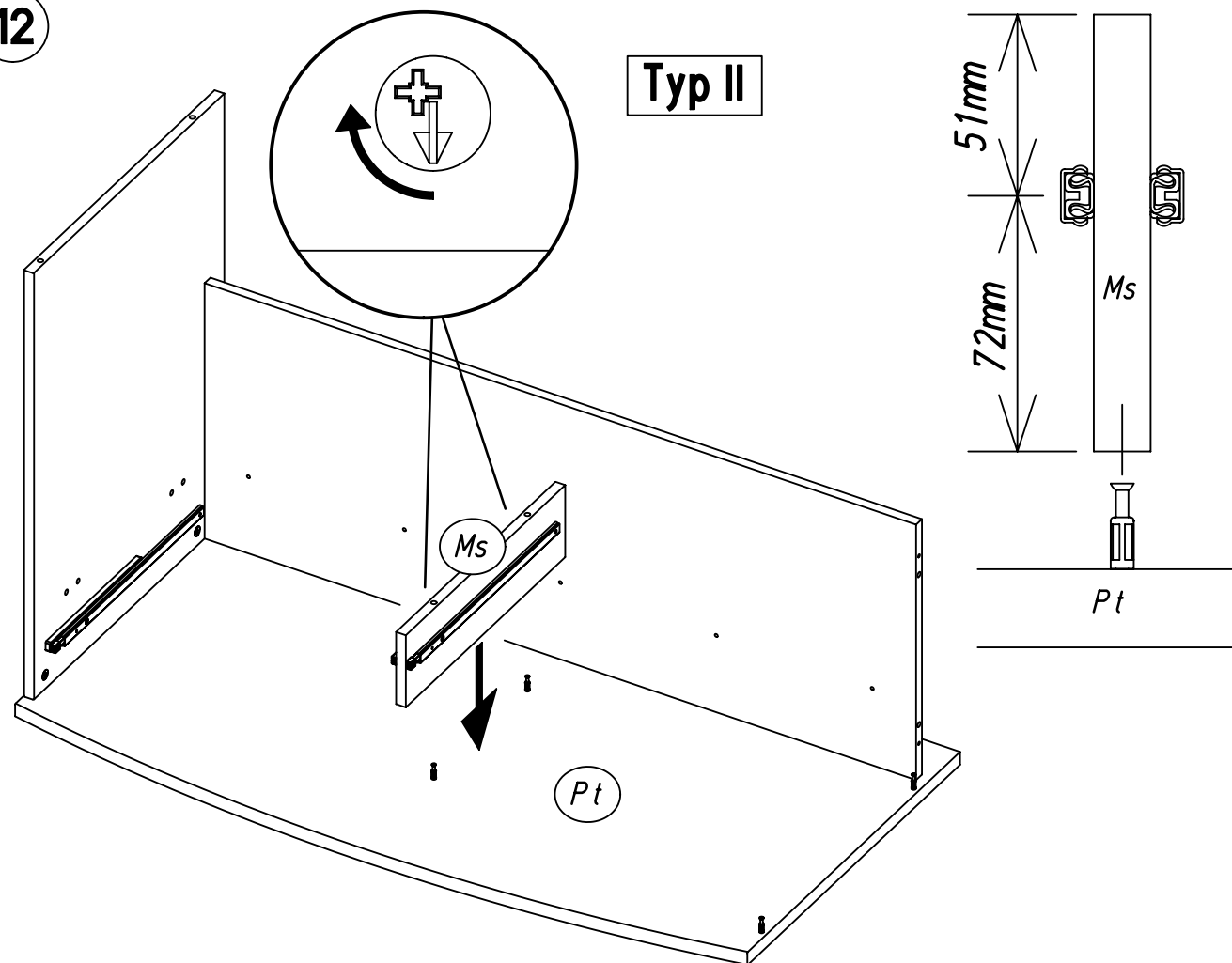

14 233

Typ I Typ II

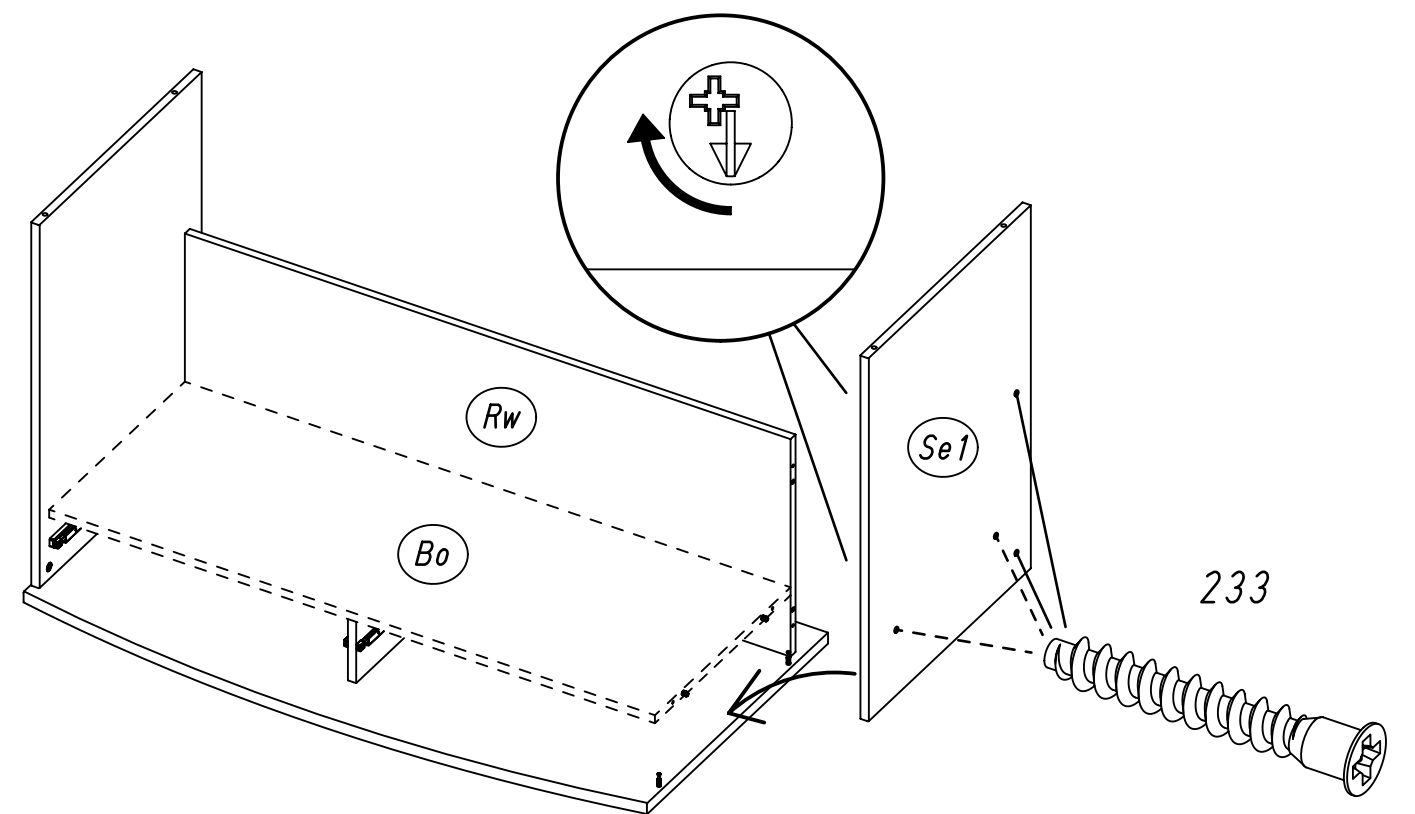

15

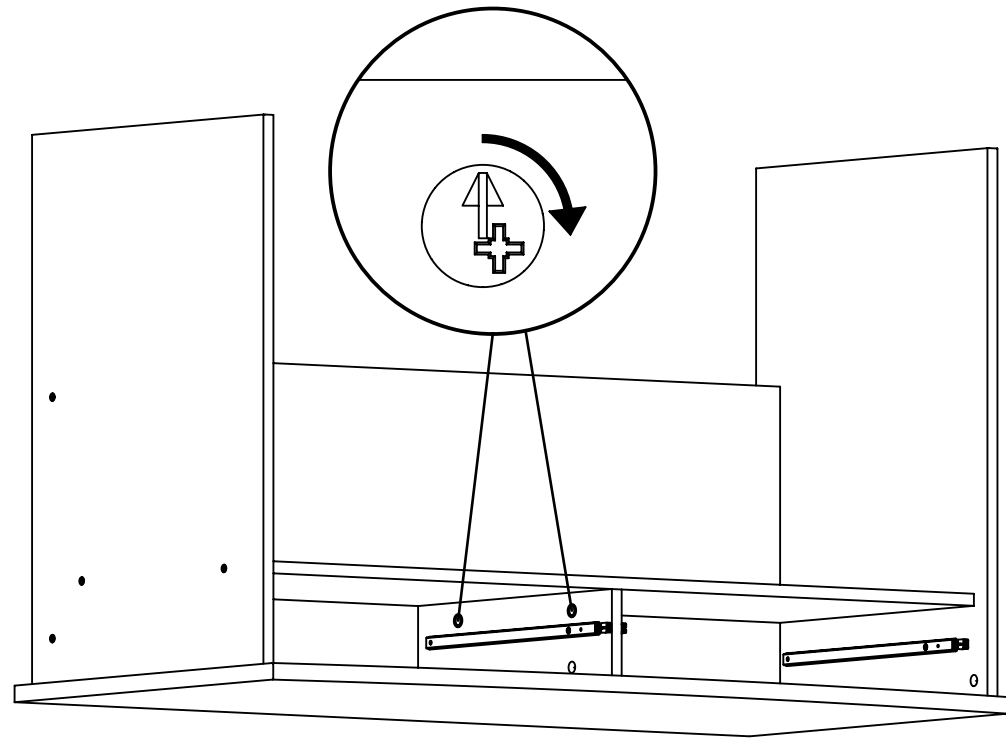

Typ II

16

447

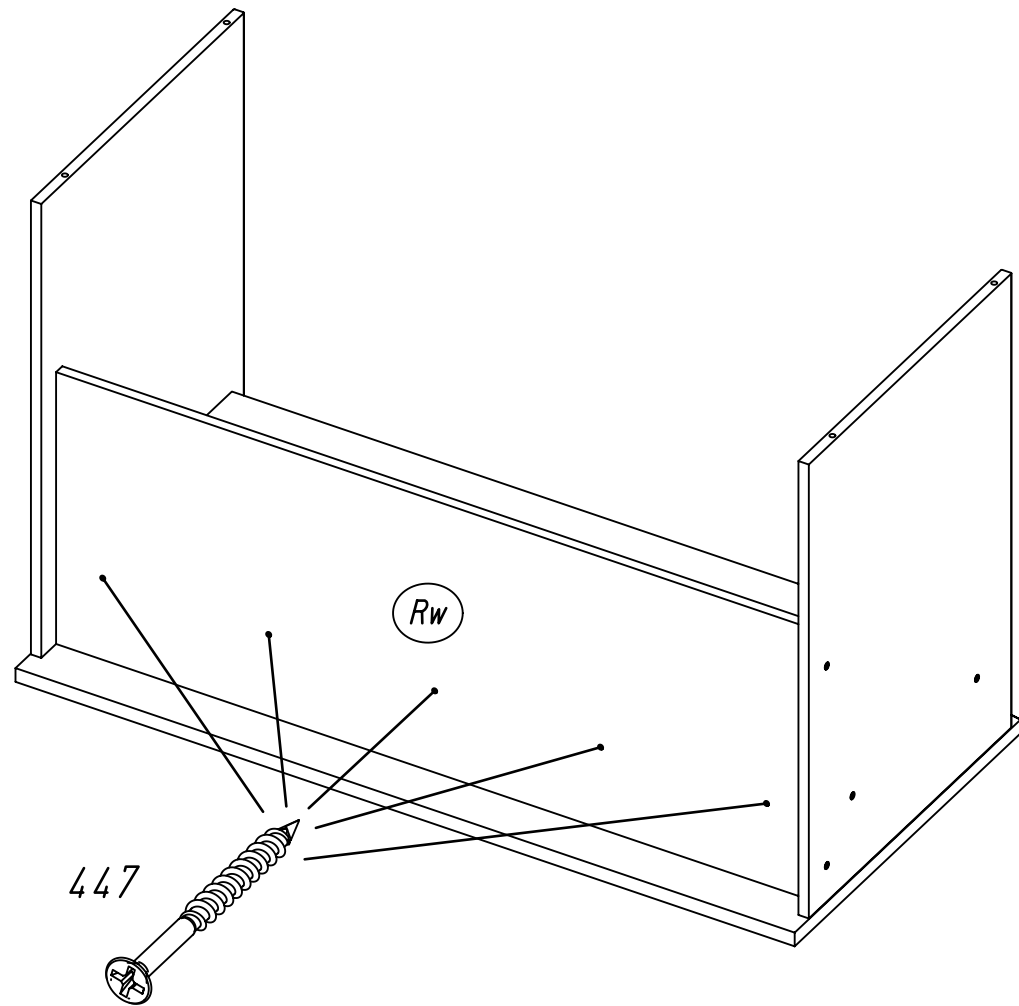

17

568

Typ II

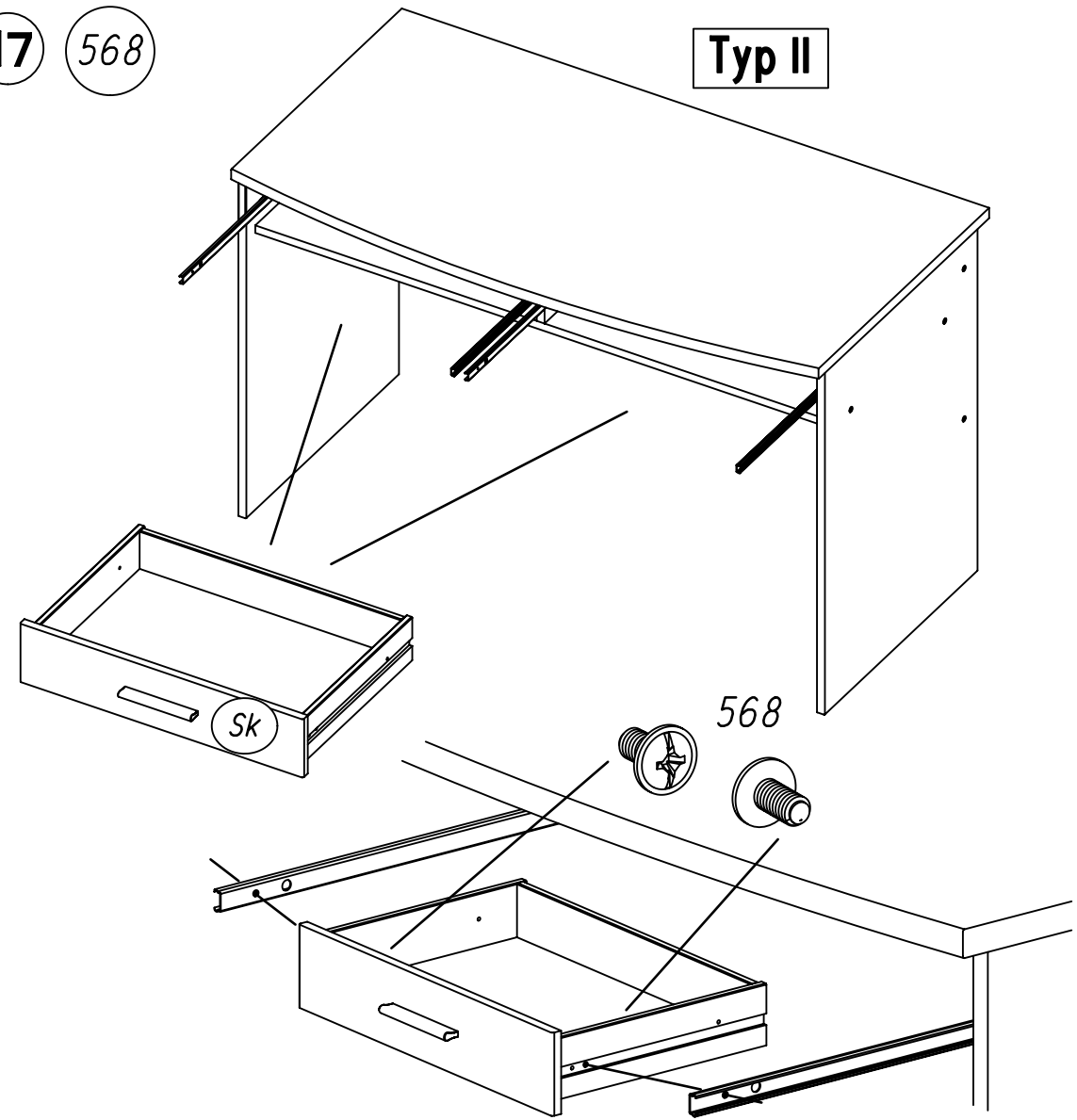

18

77

271

Typ I Typ II

