

Typ I

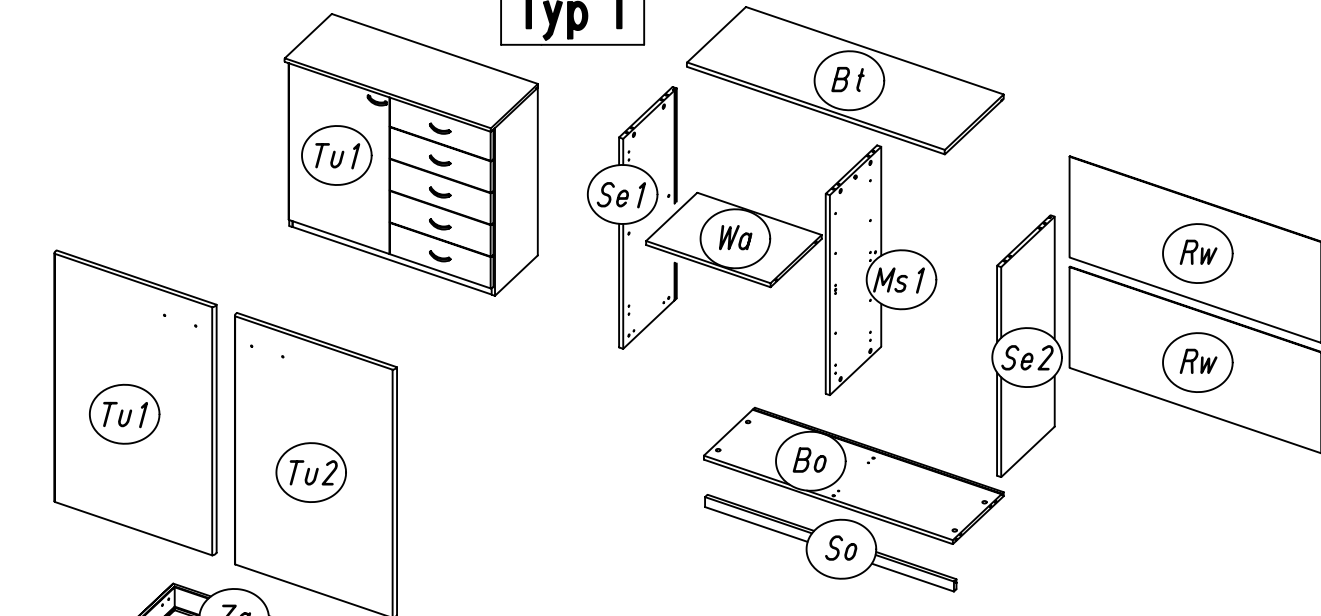

Typ II

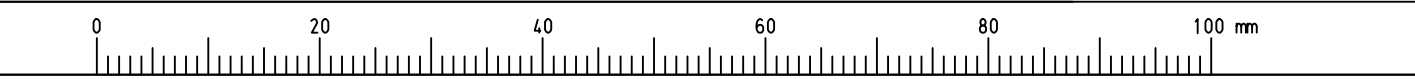

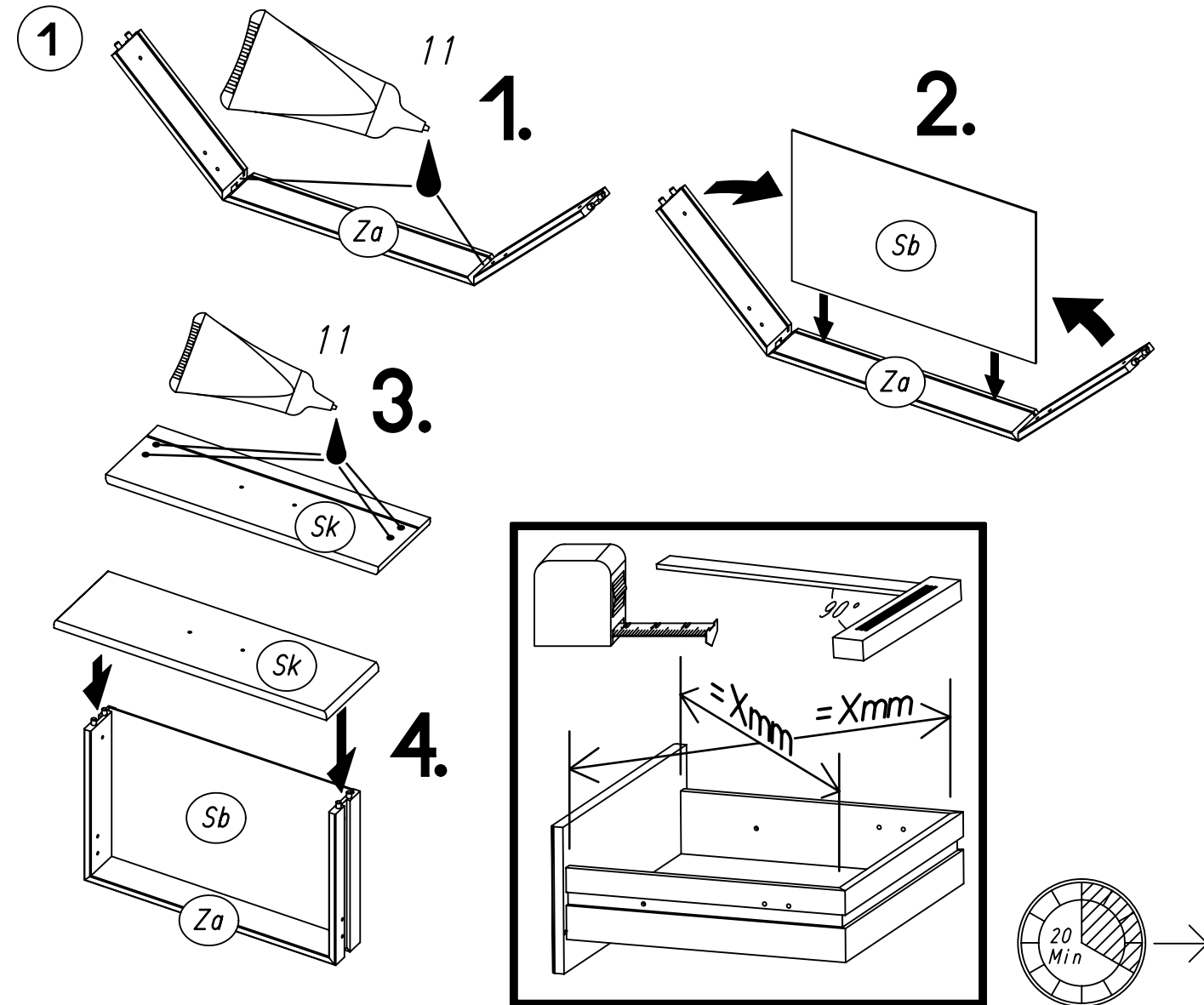
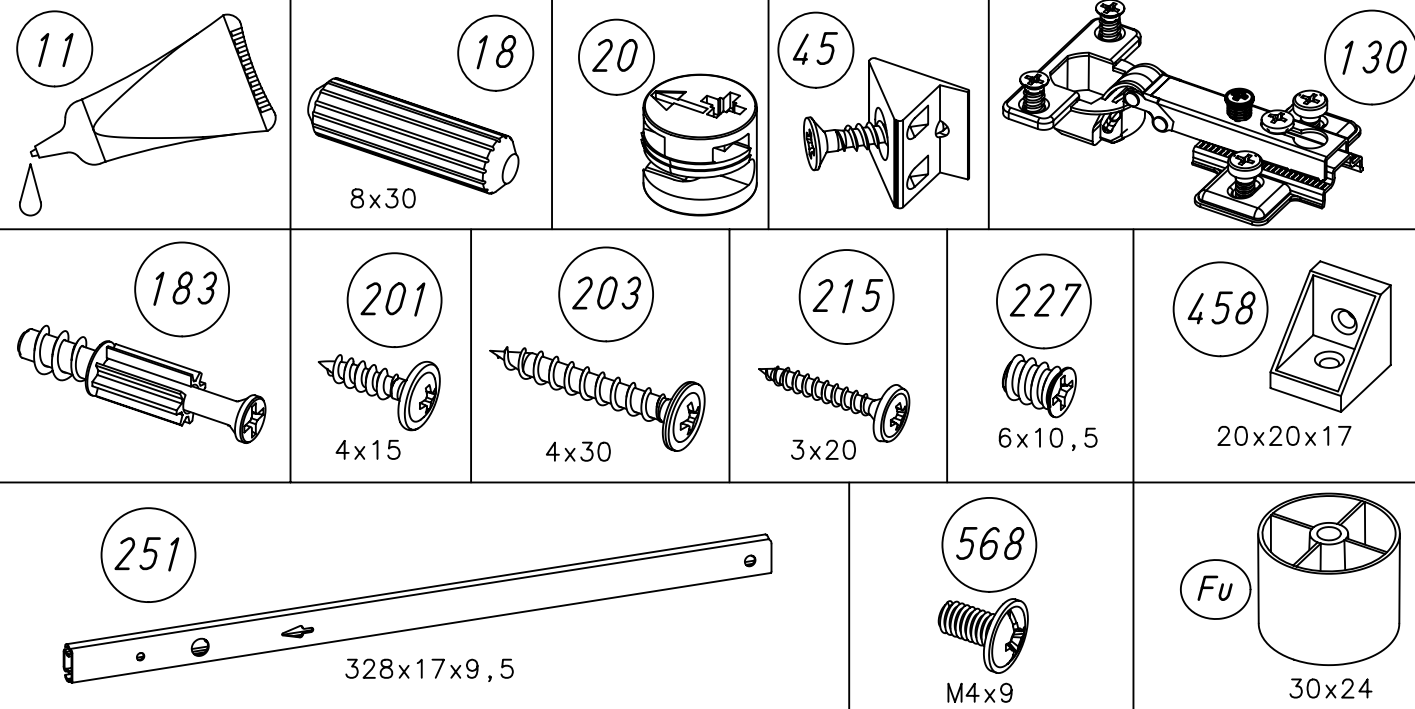
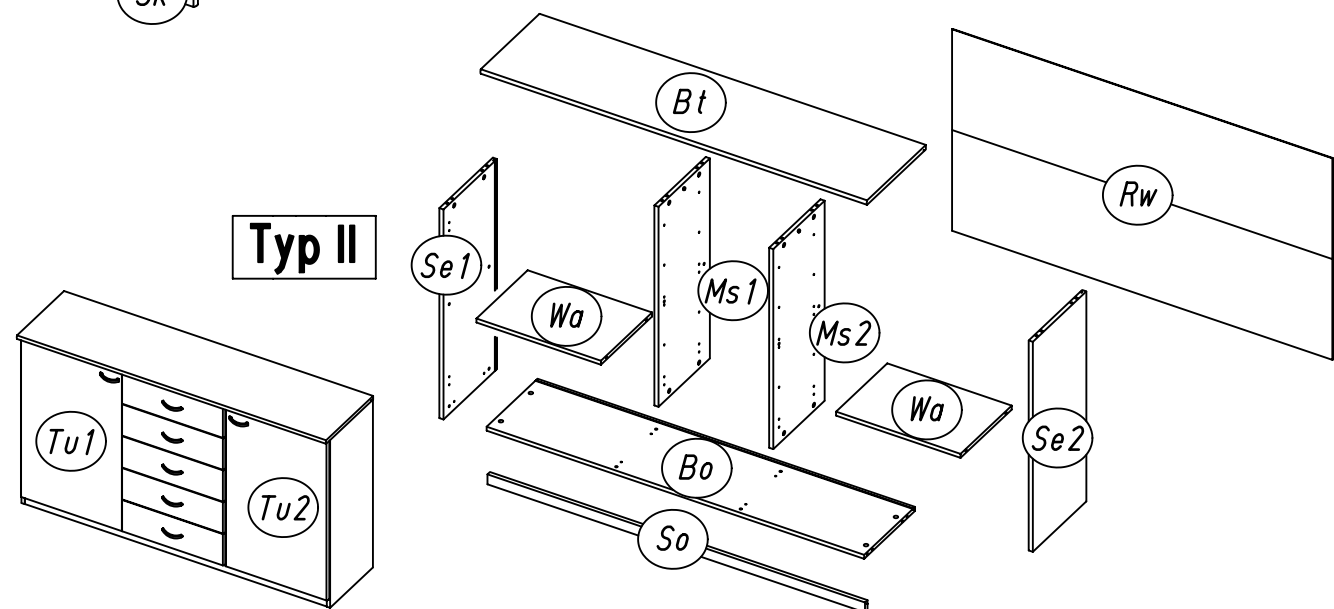
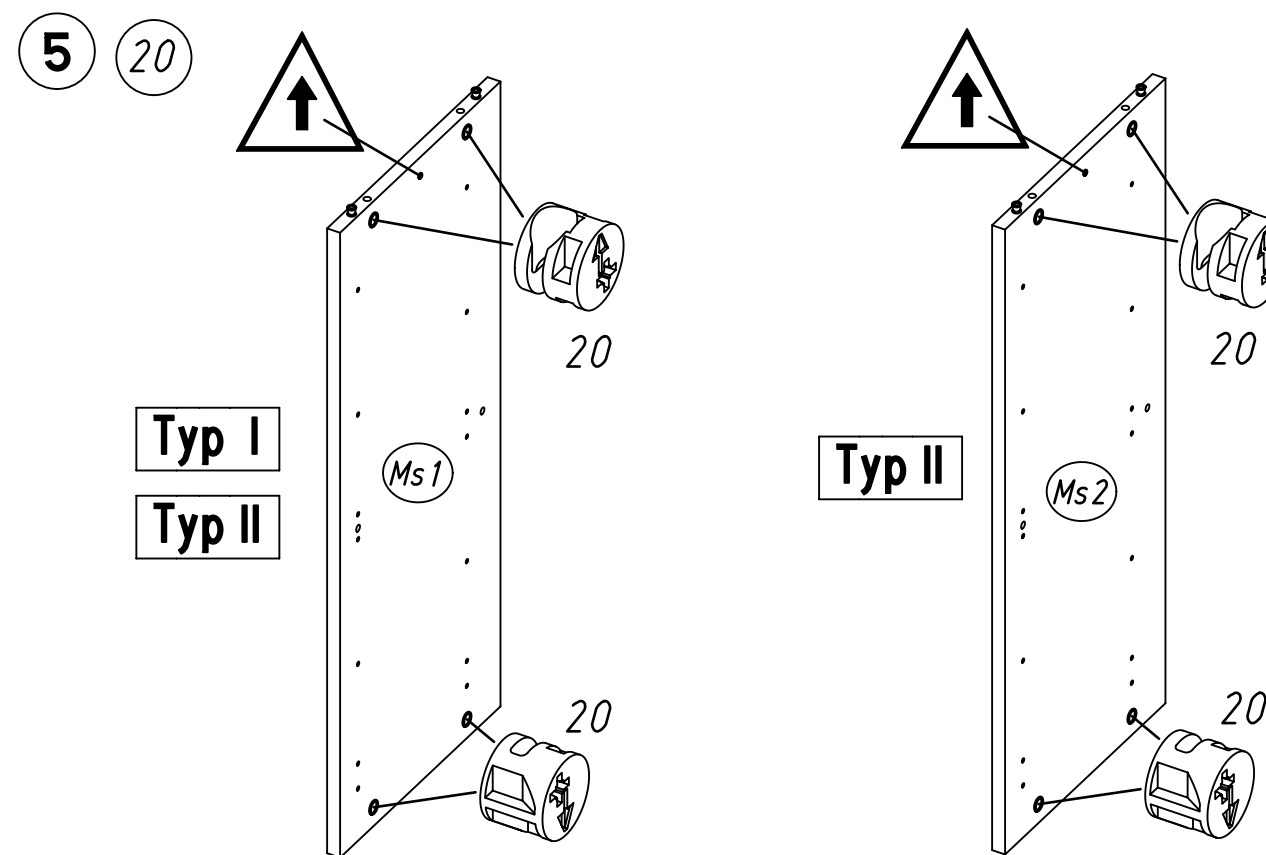
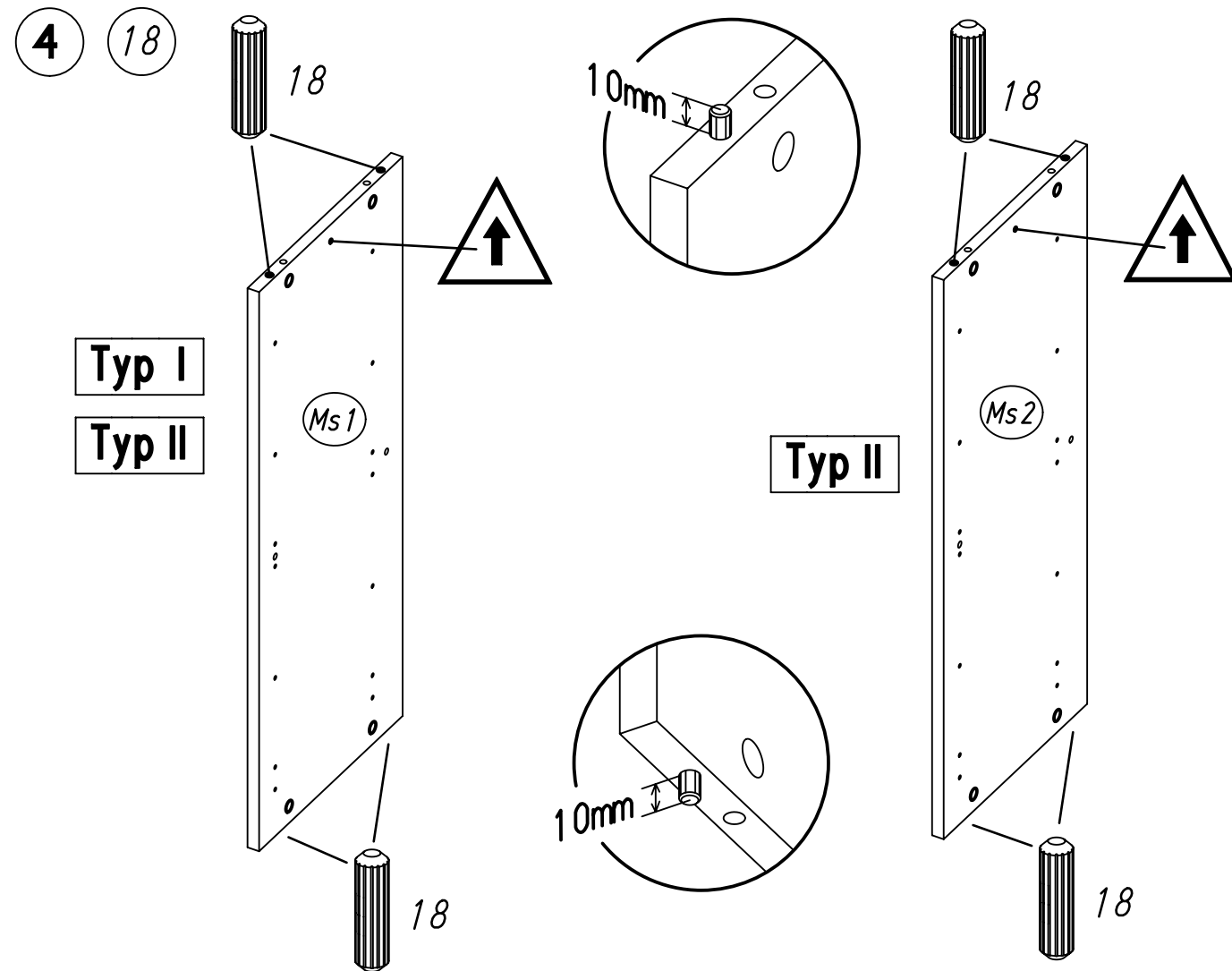
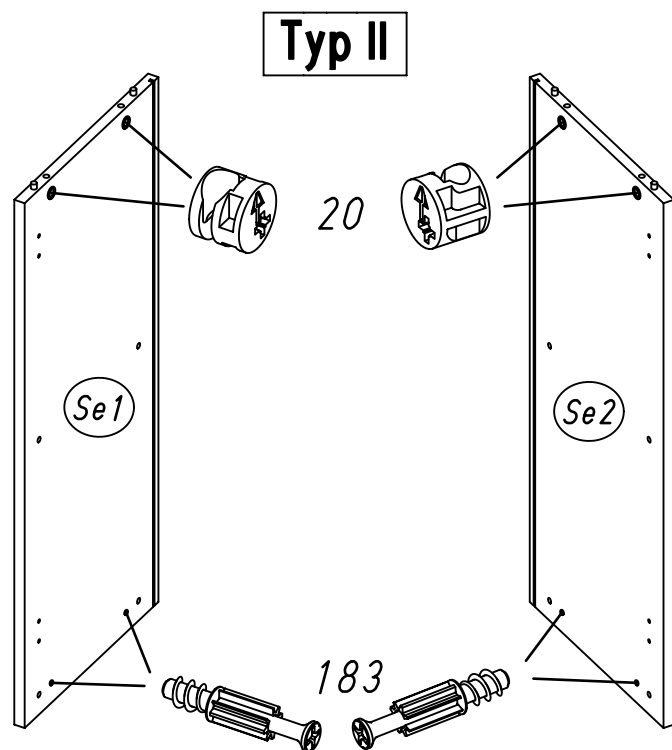
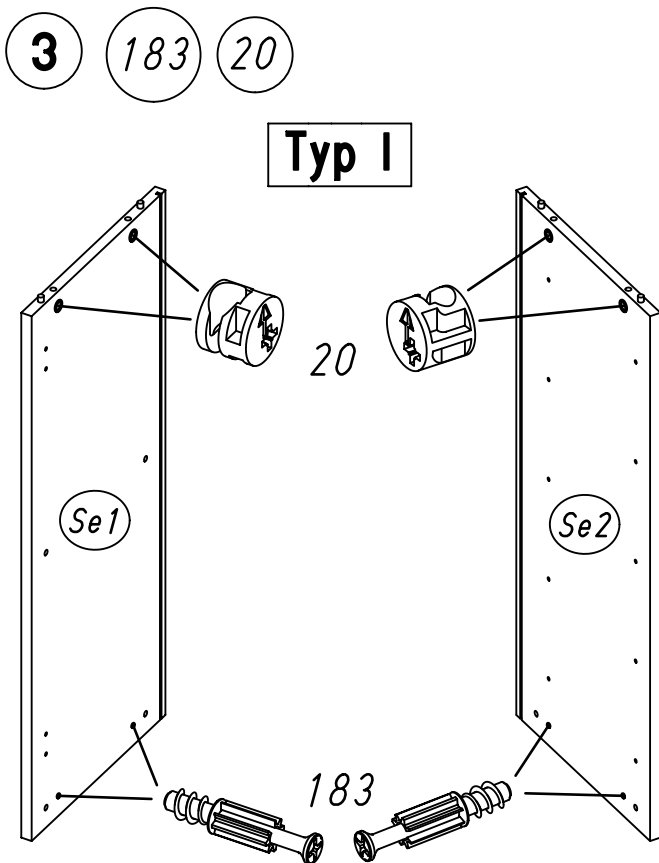
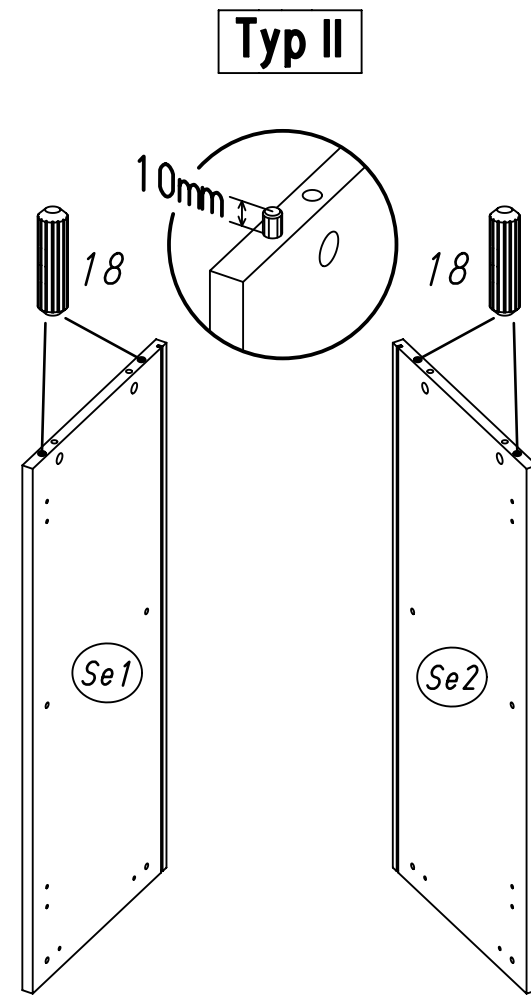
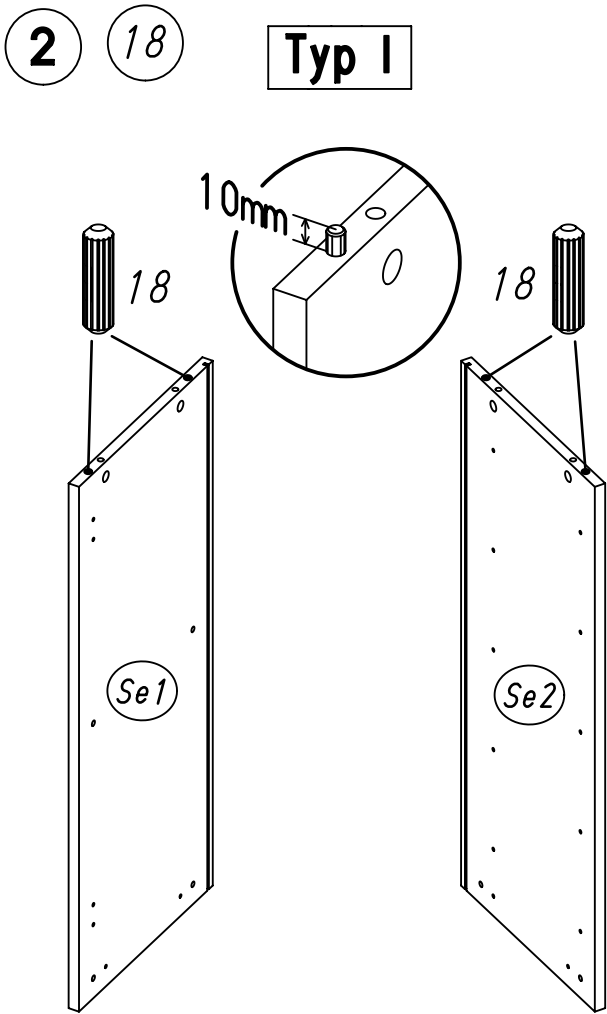

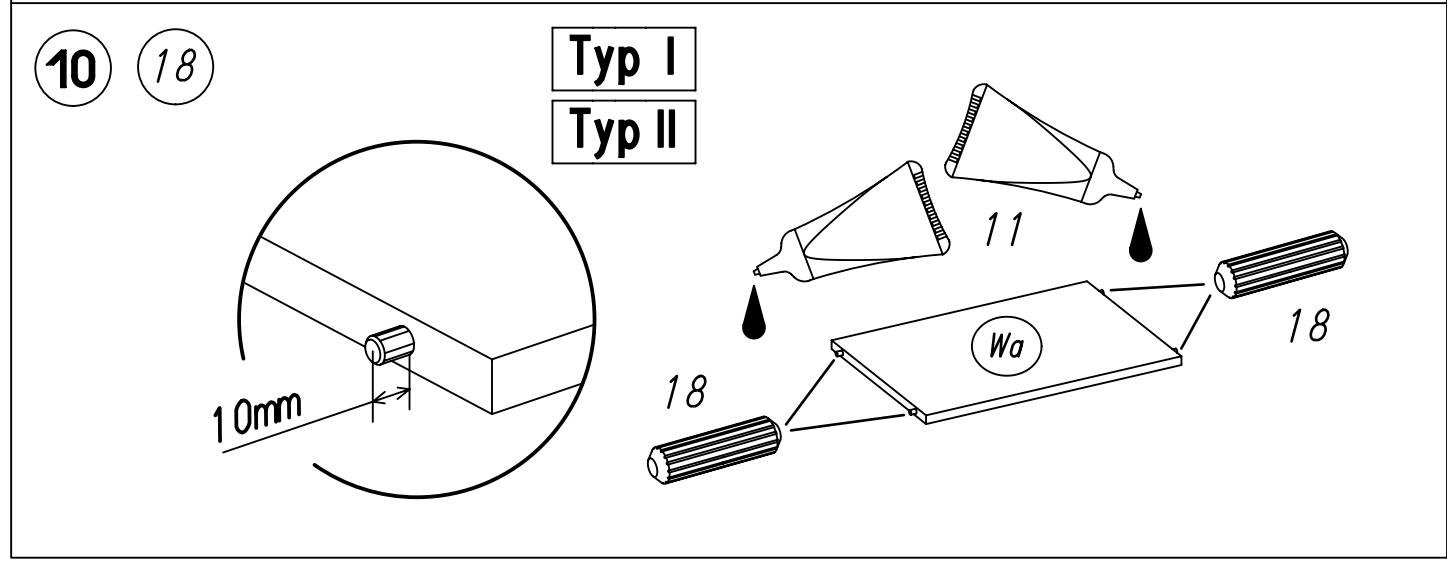
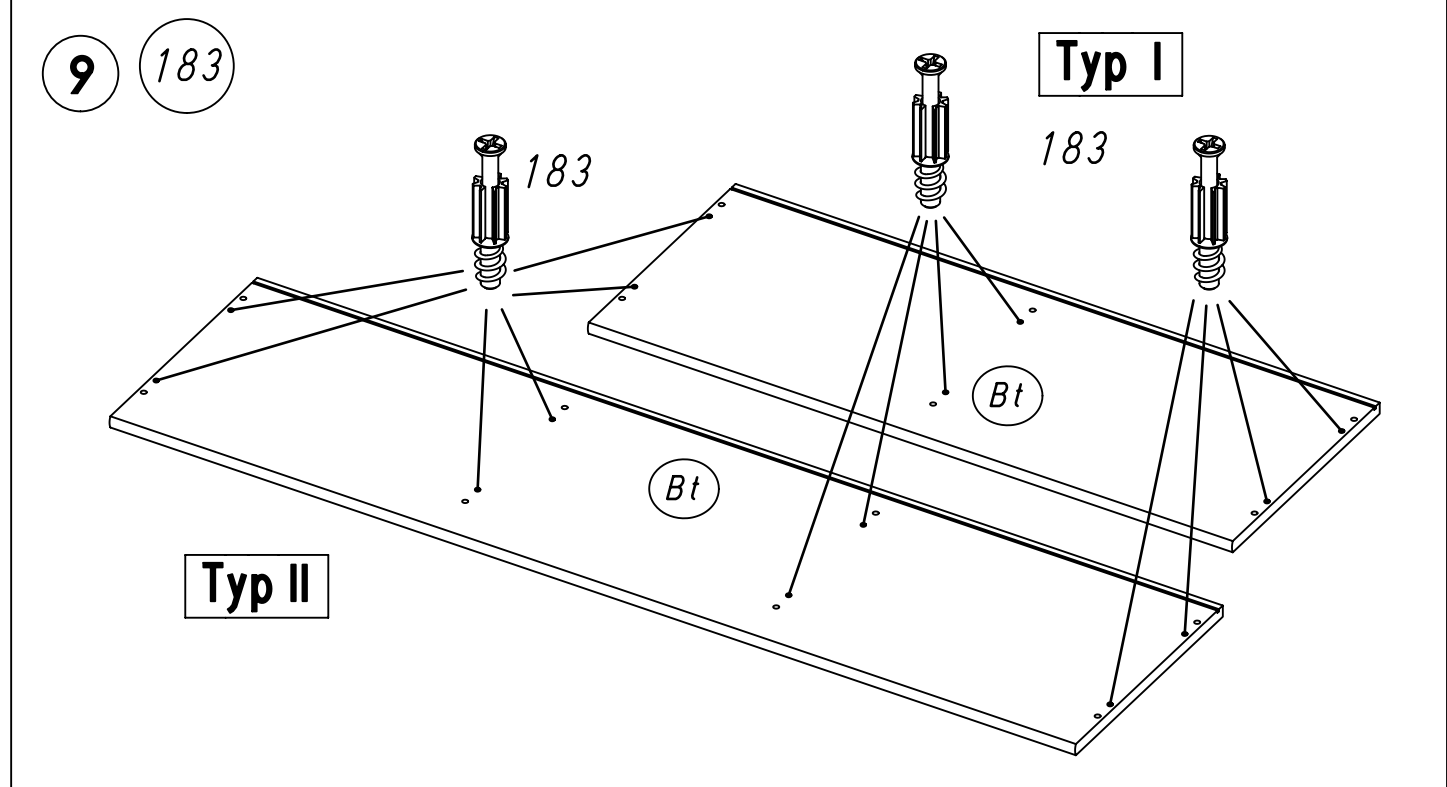
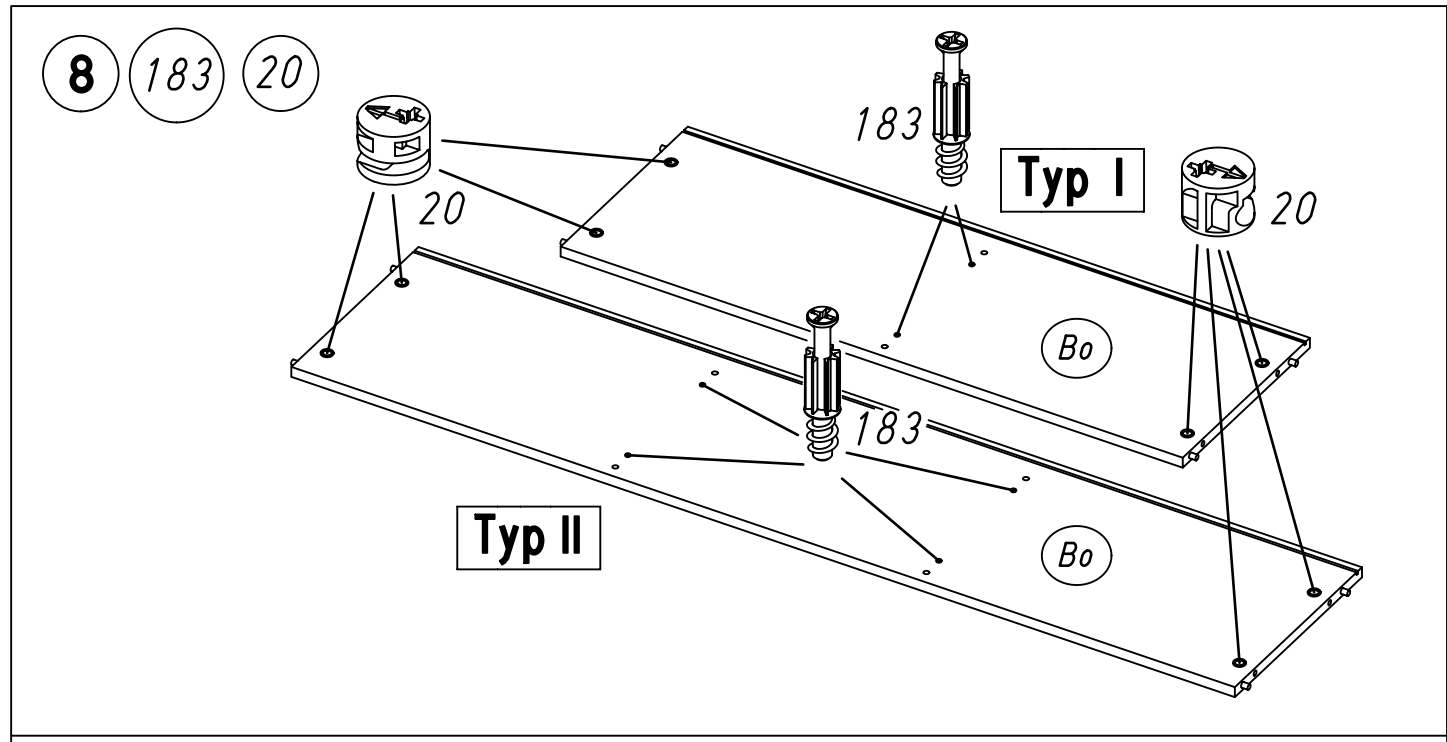
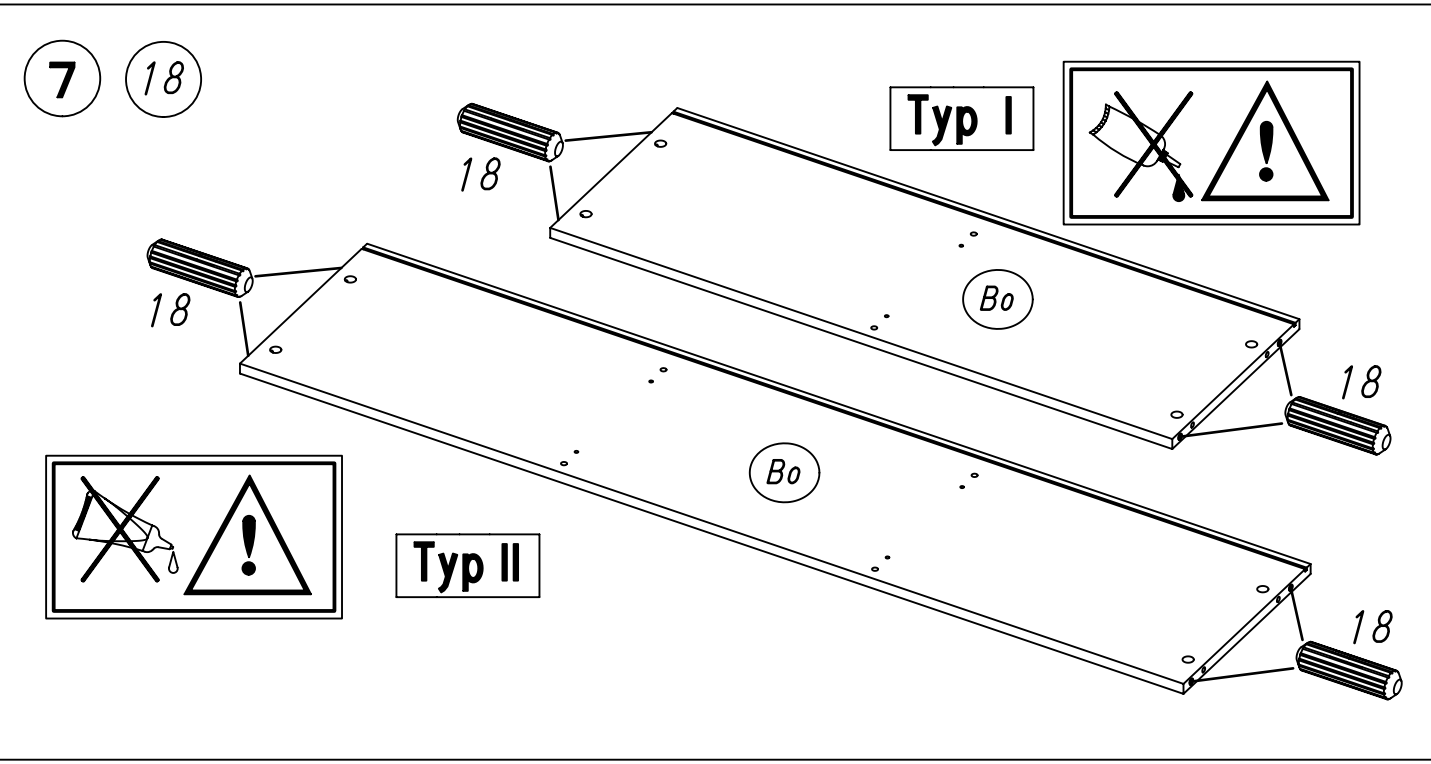
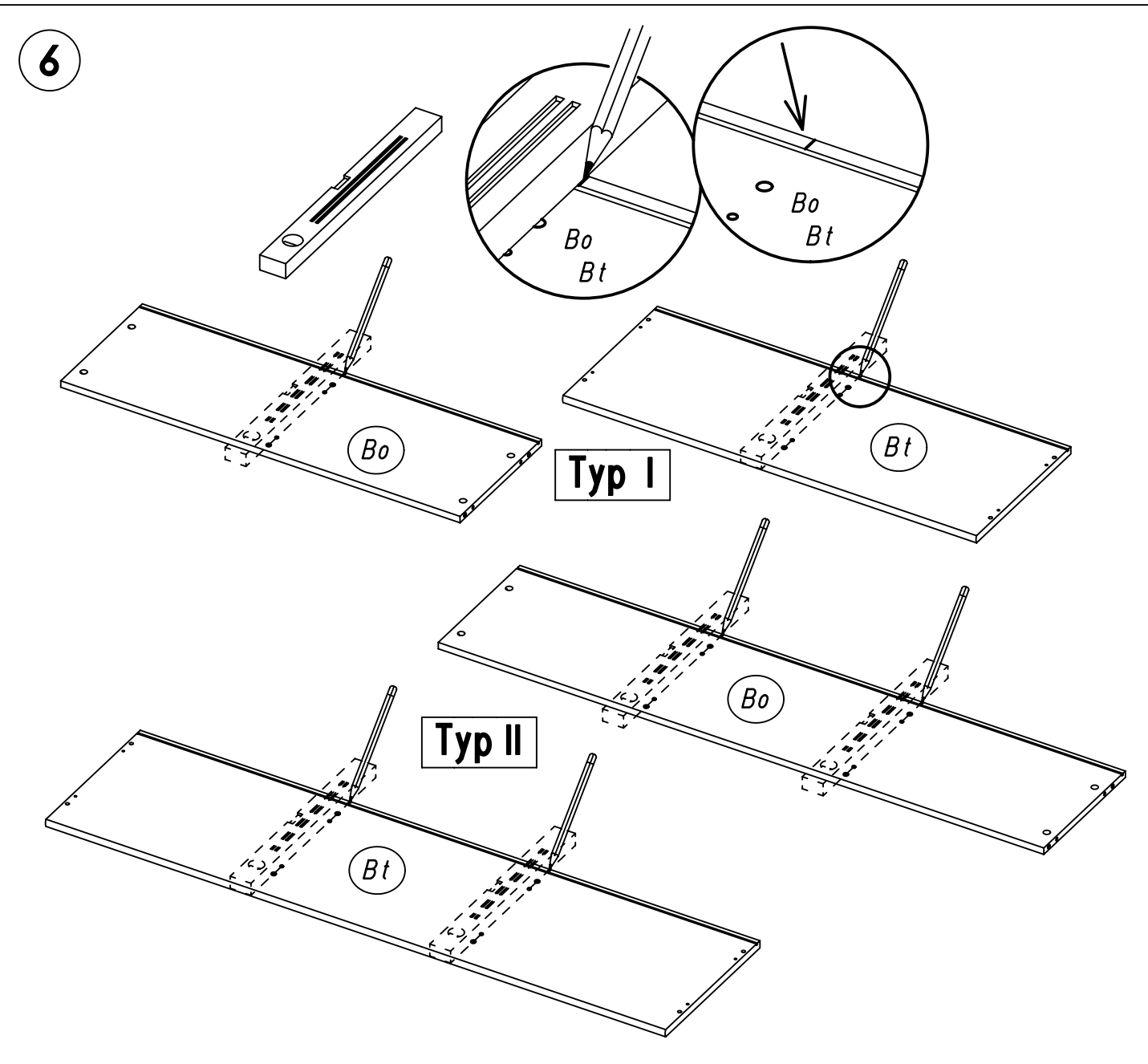

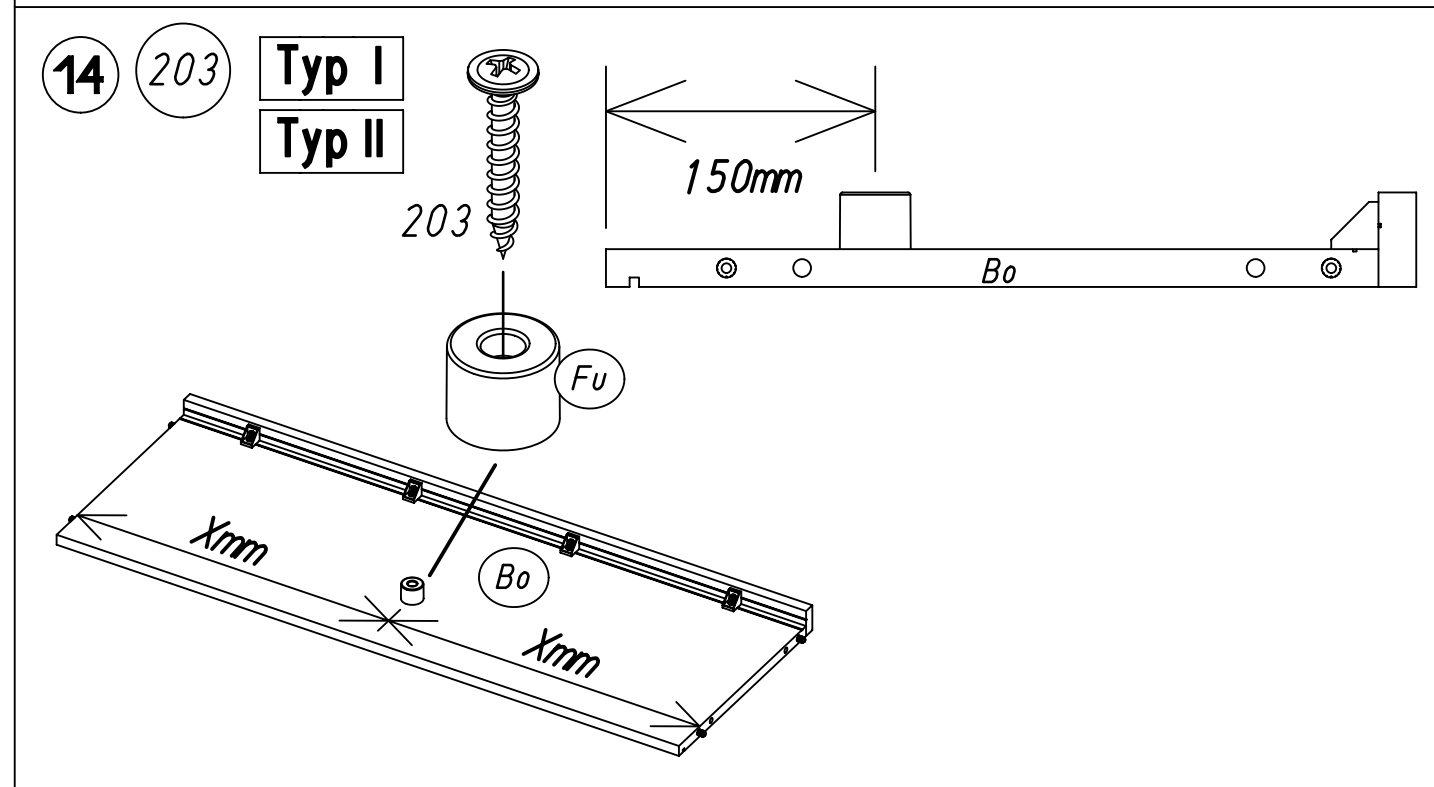
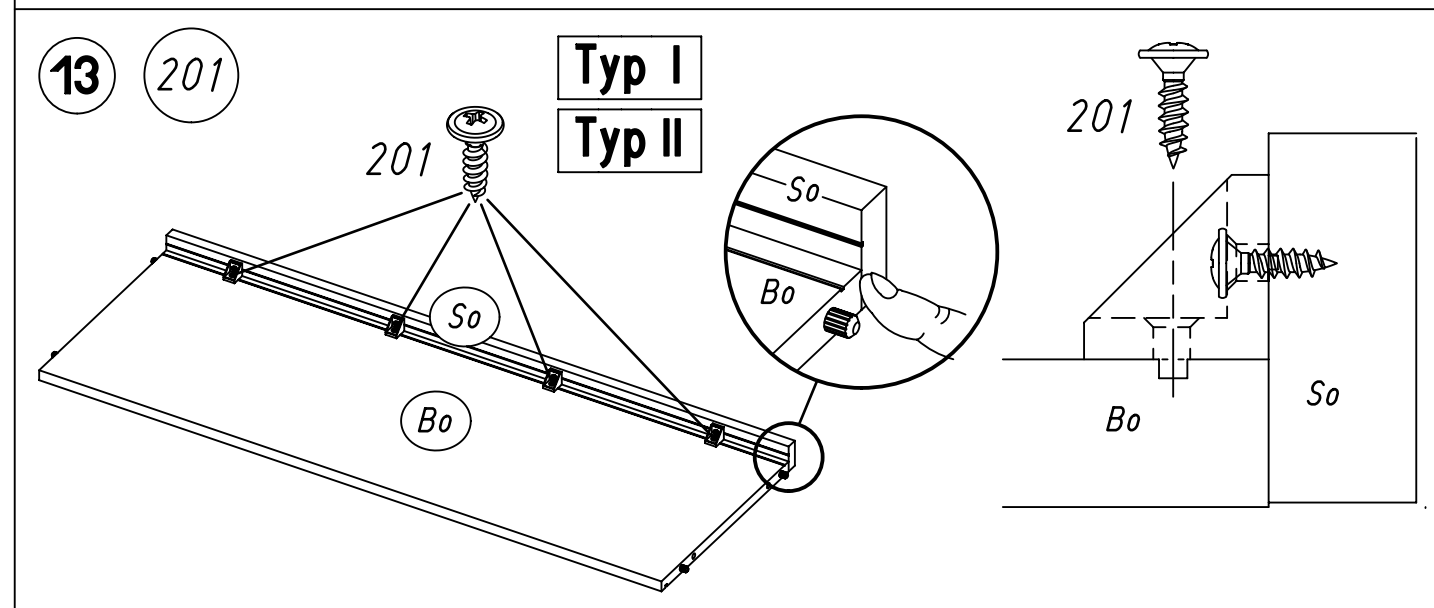
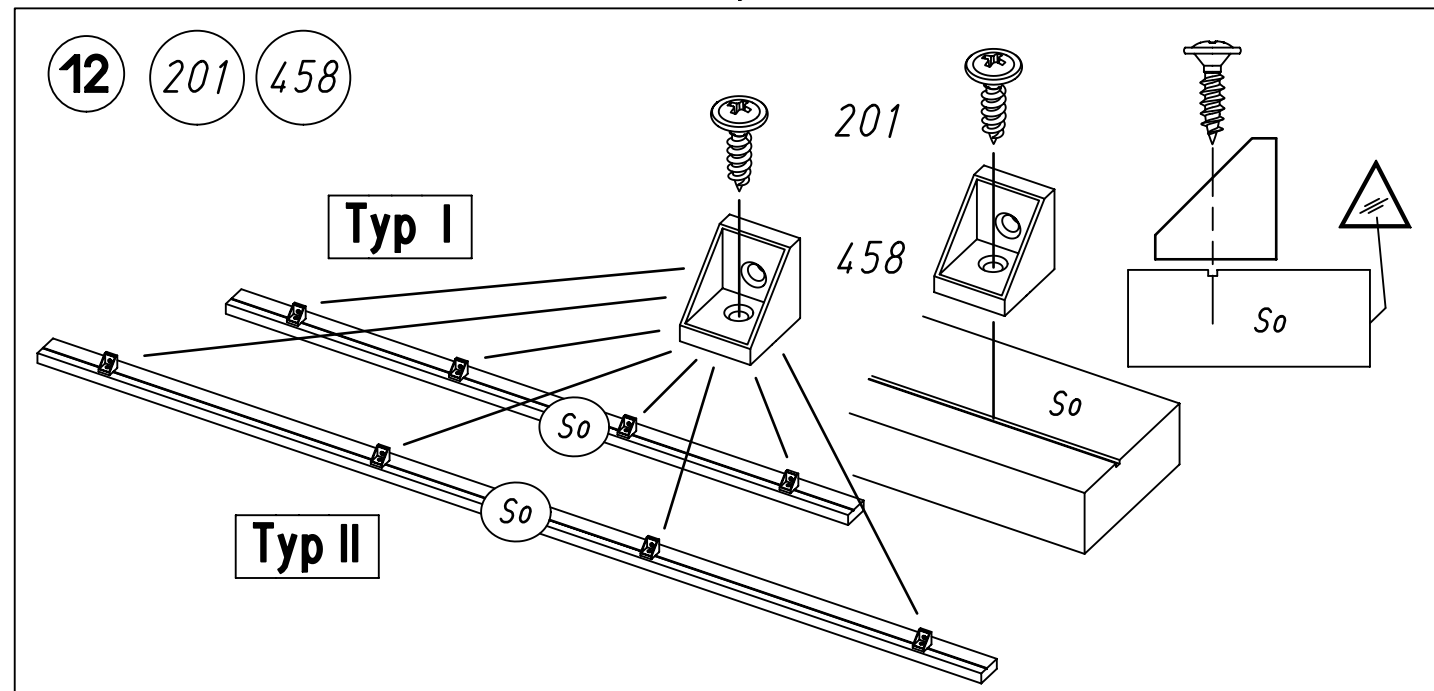
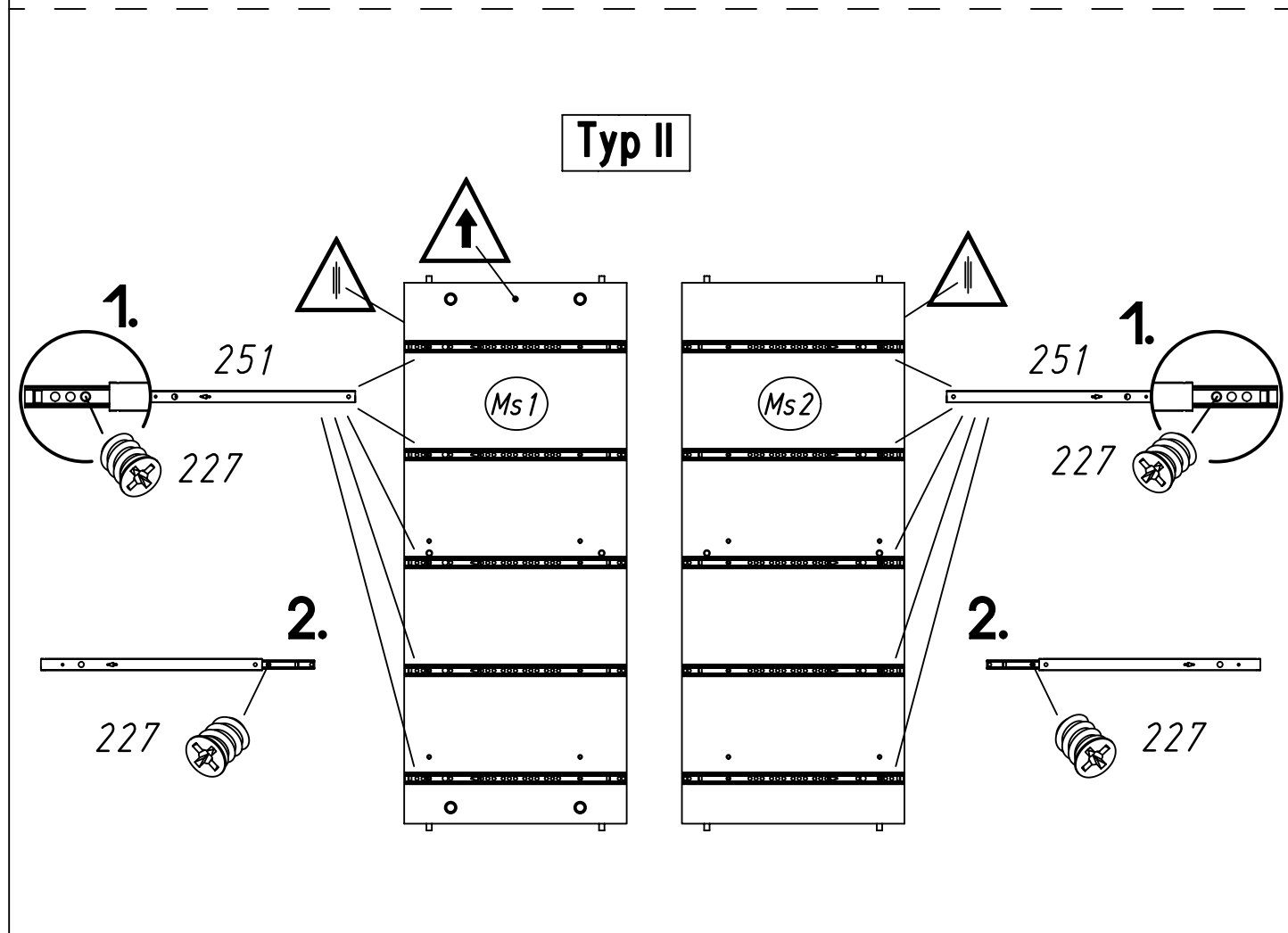
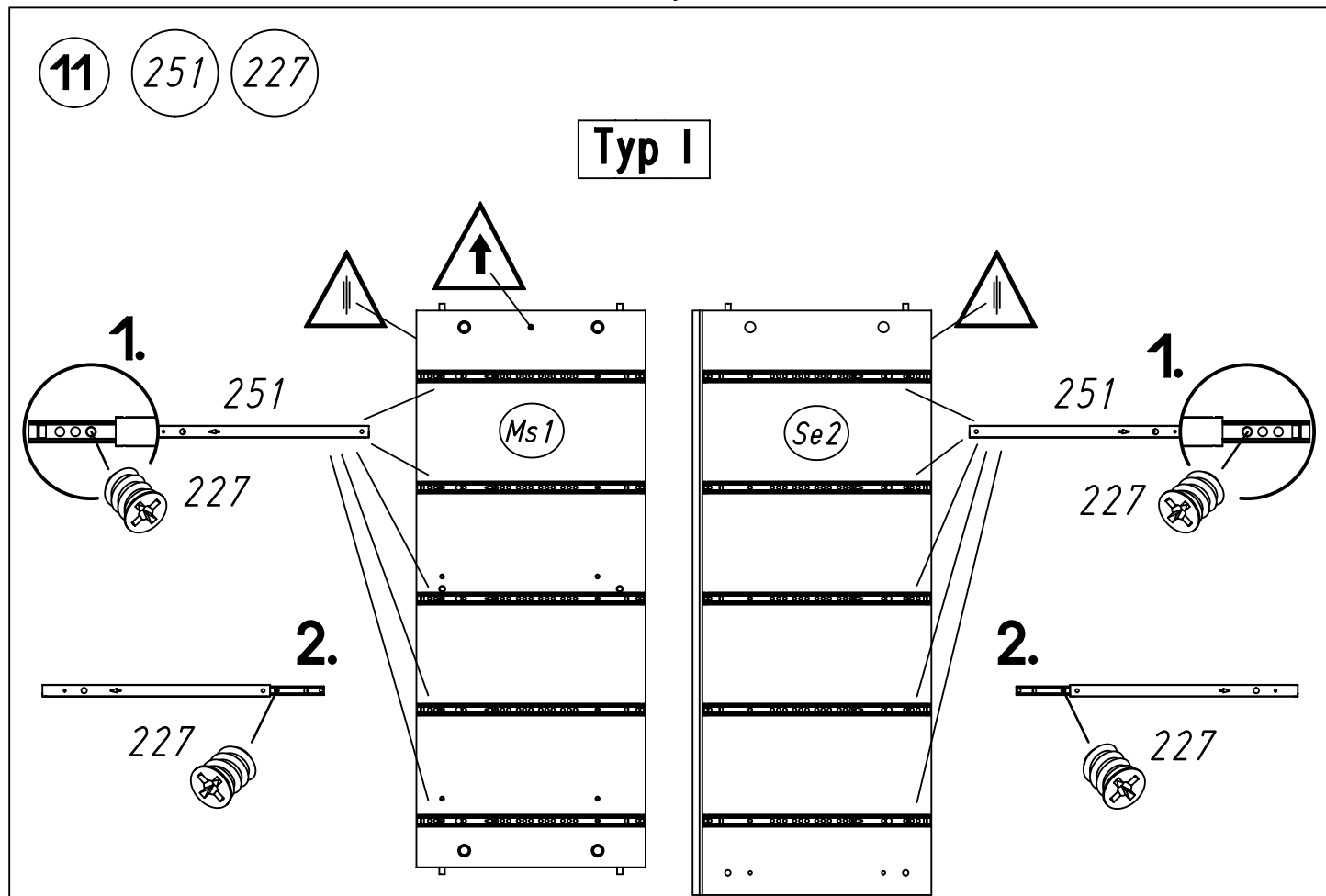

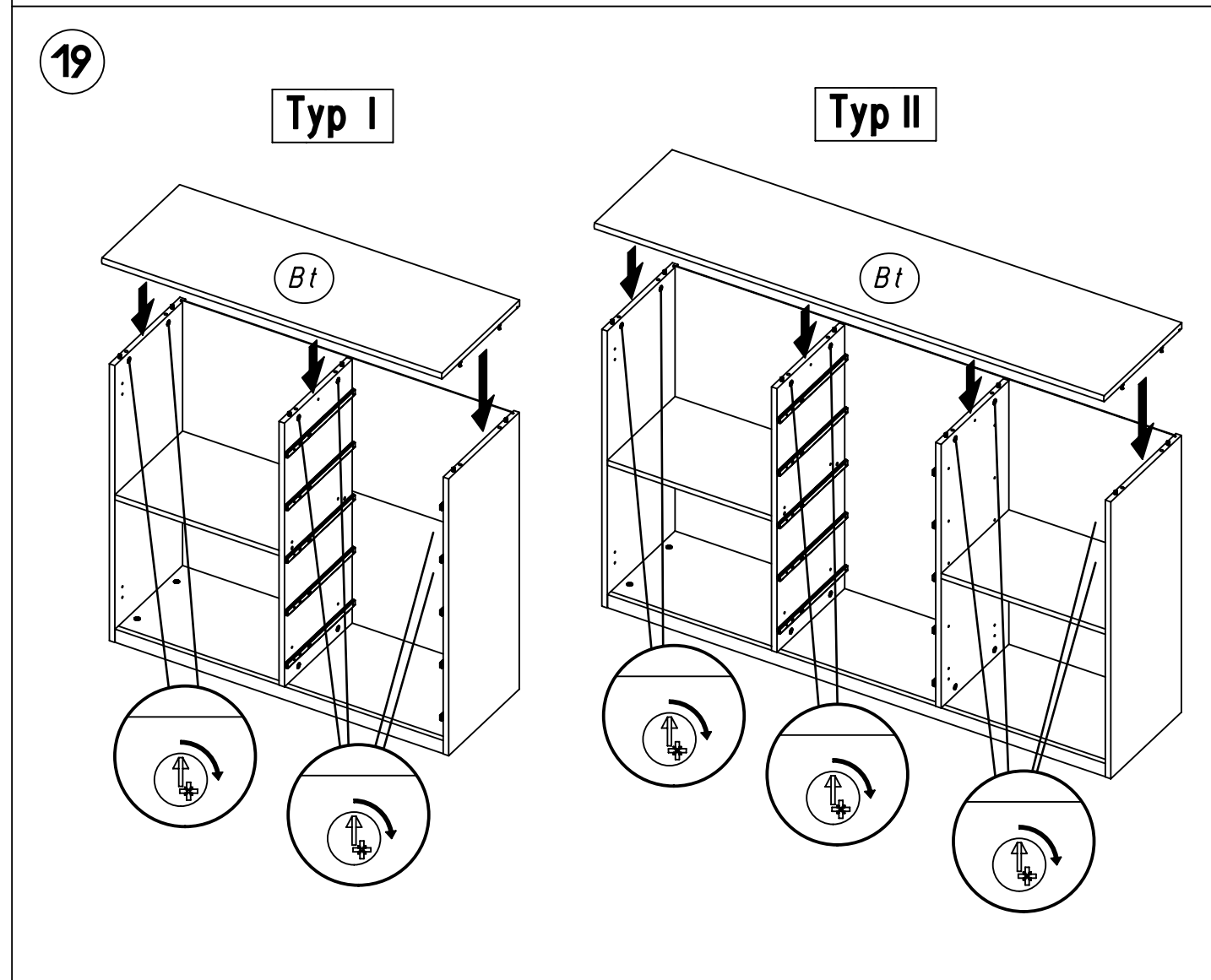
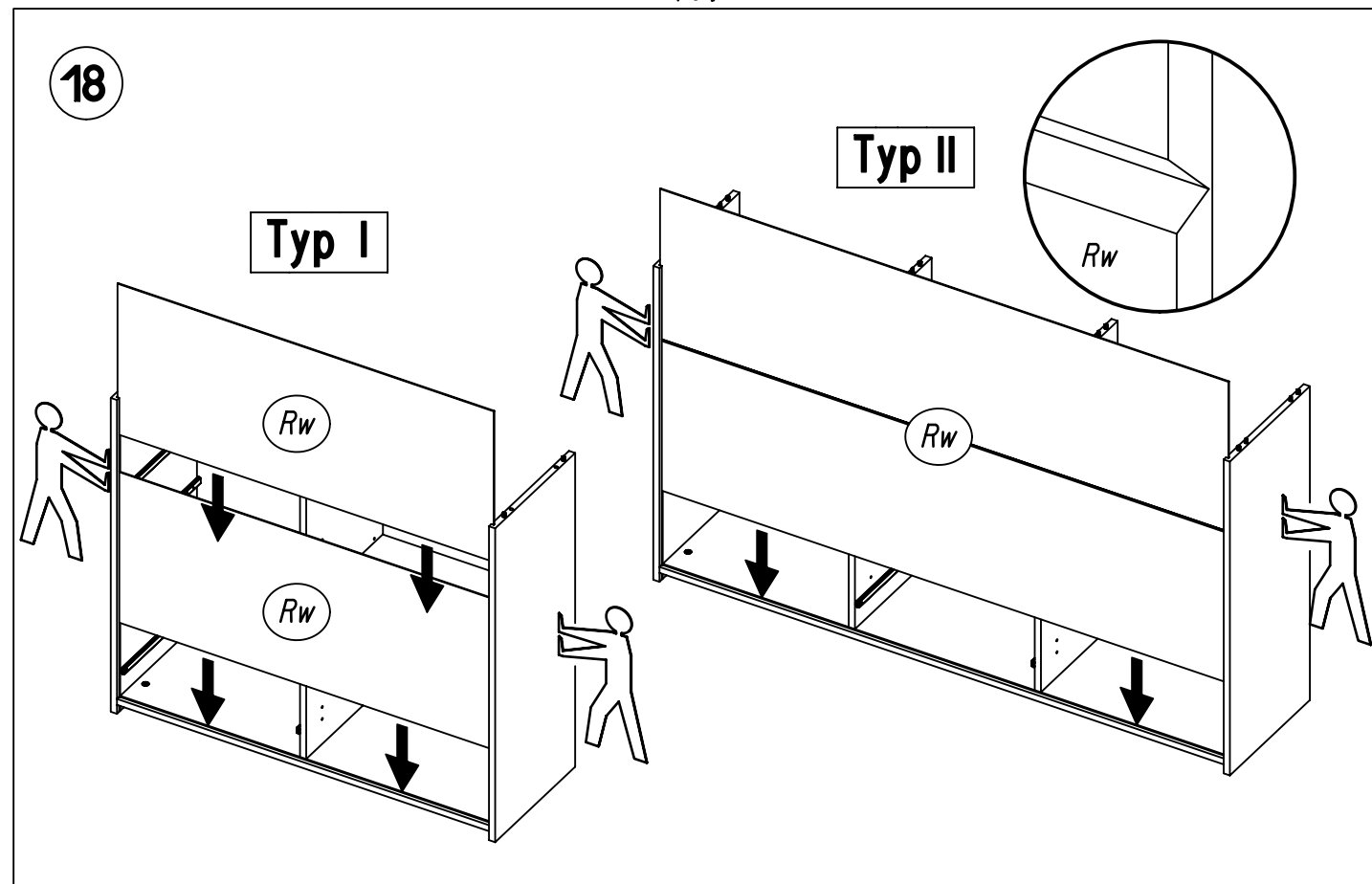
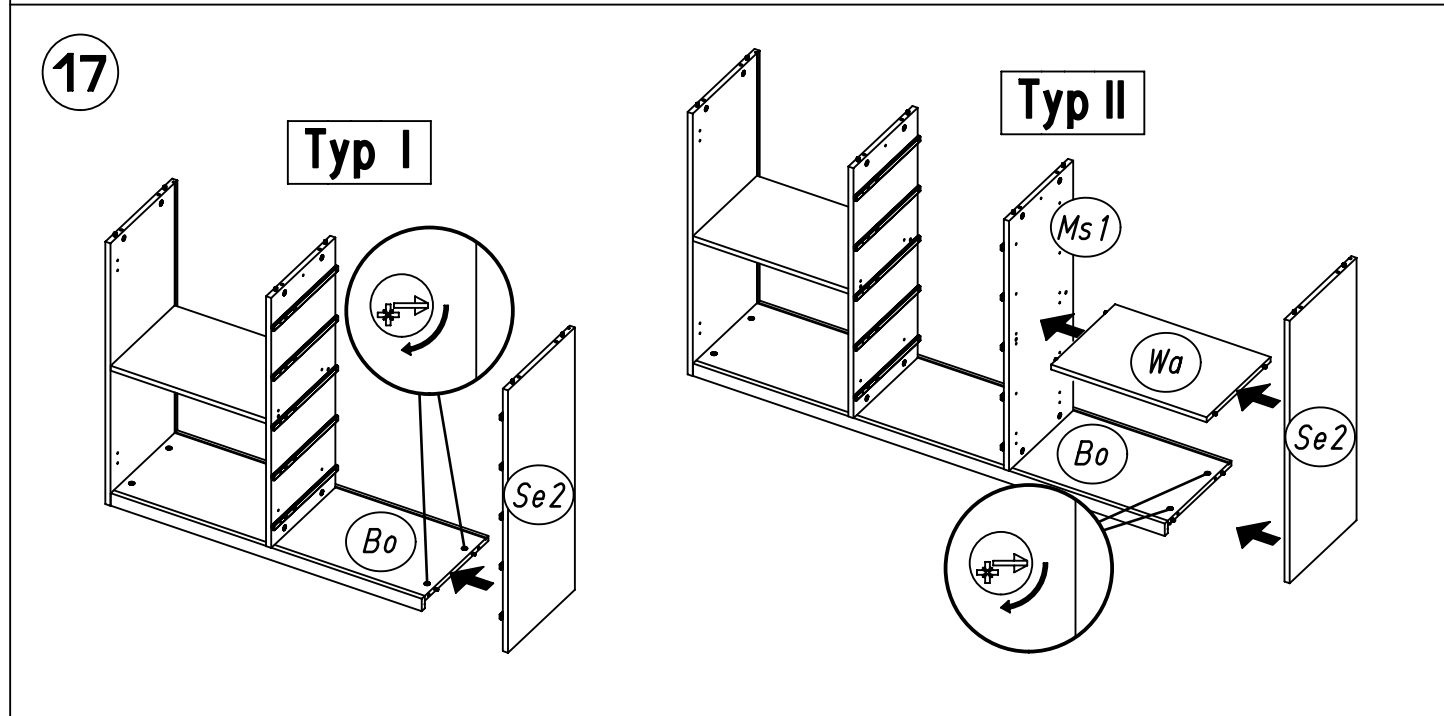
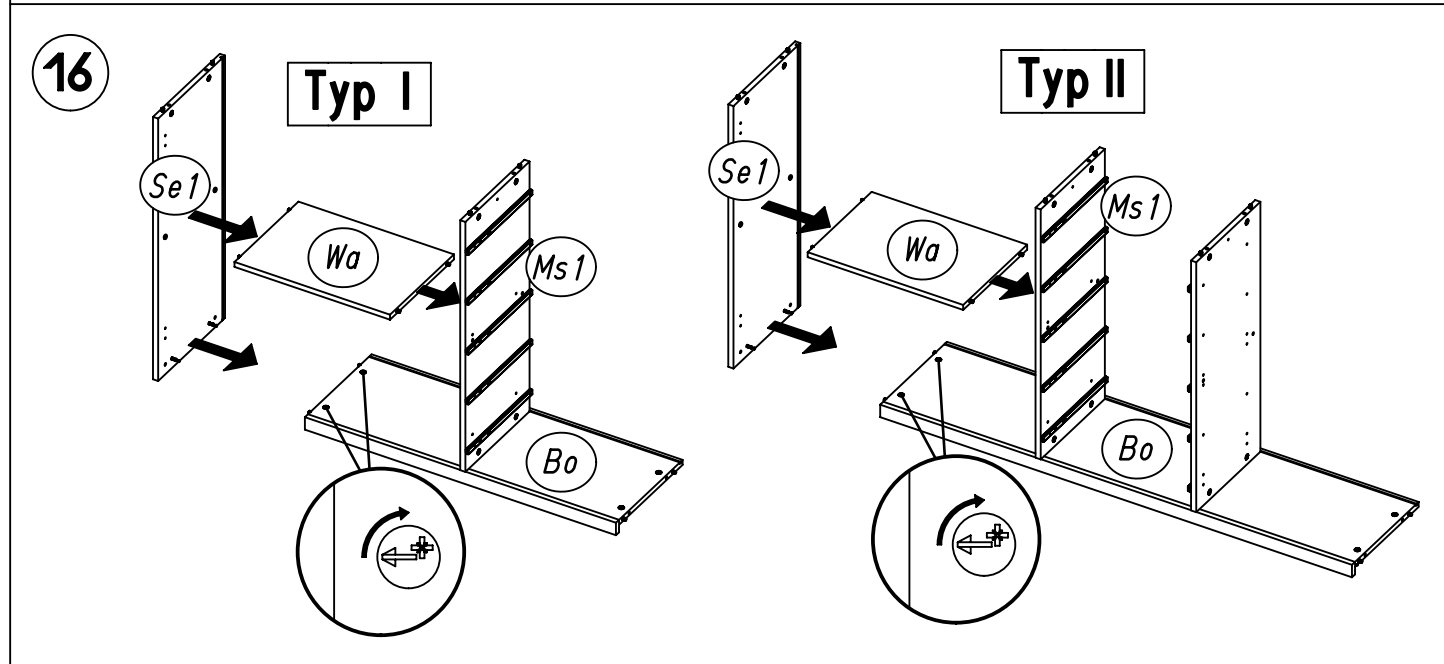
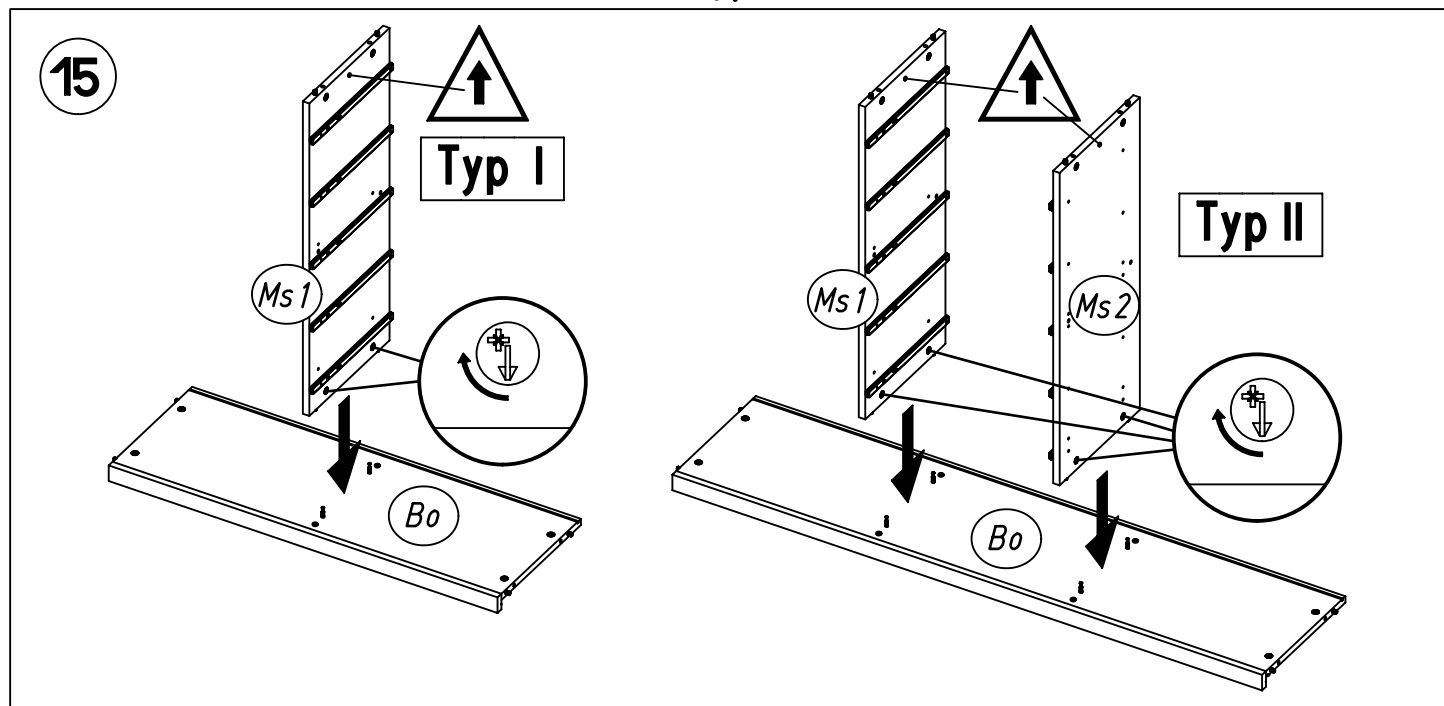

20 45

Typ I

Typ II

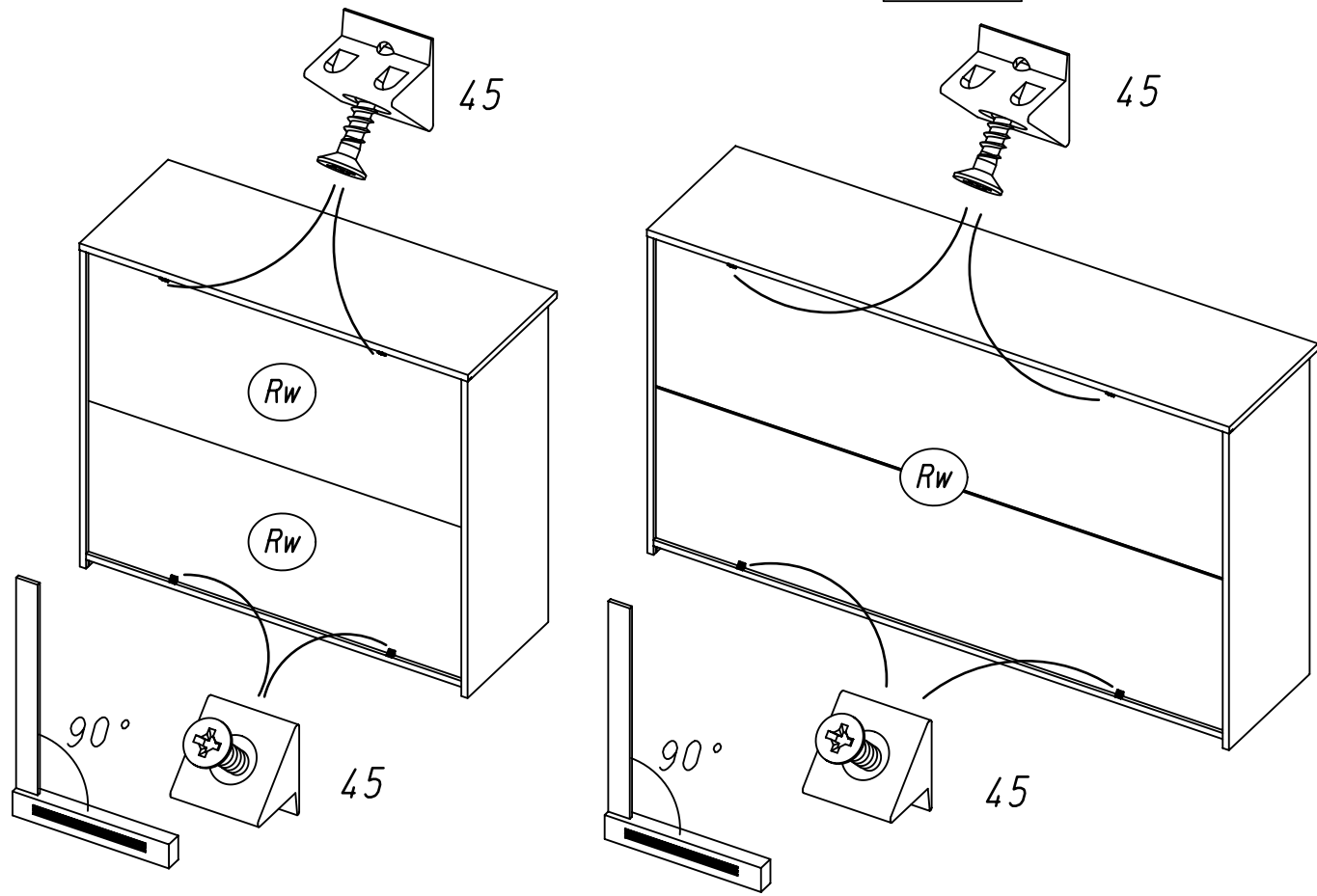

22 215

Typ I

Typ II

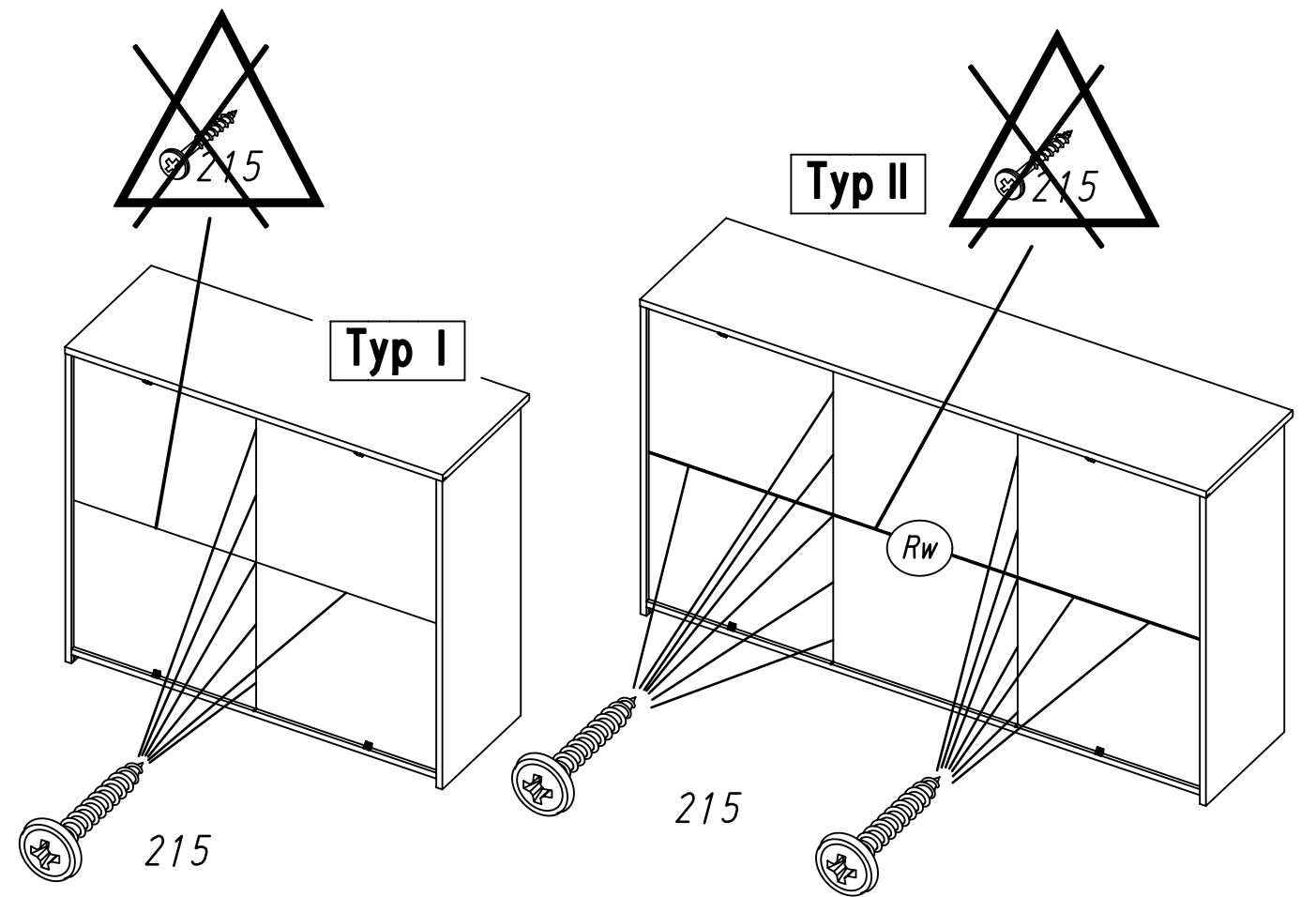

21

Typ I

Typ II

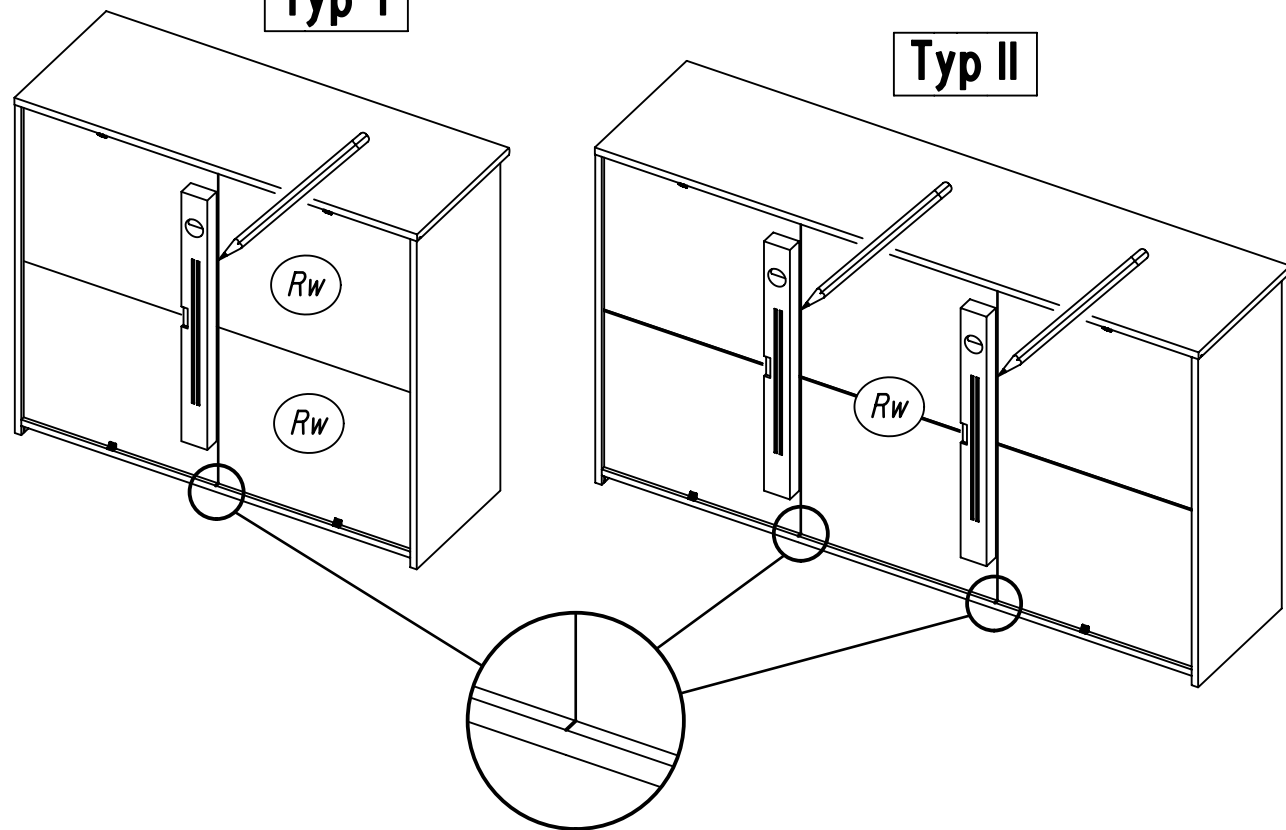

23 130

Typ I

Typ II

Typ II

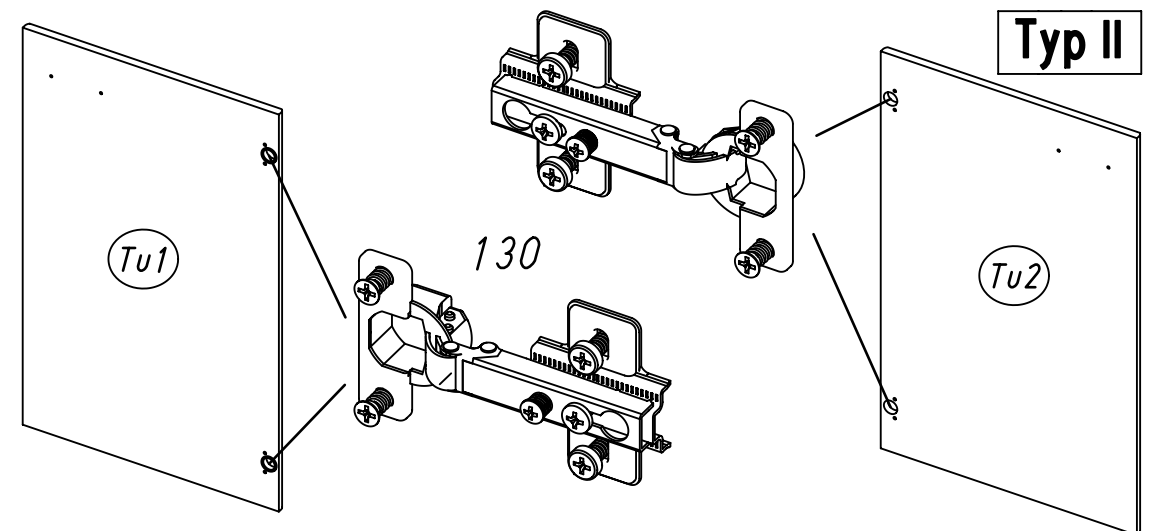

24

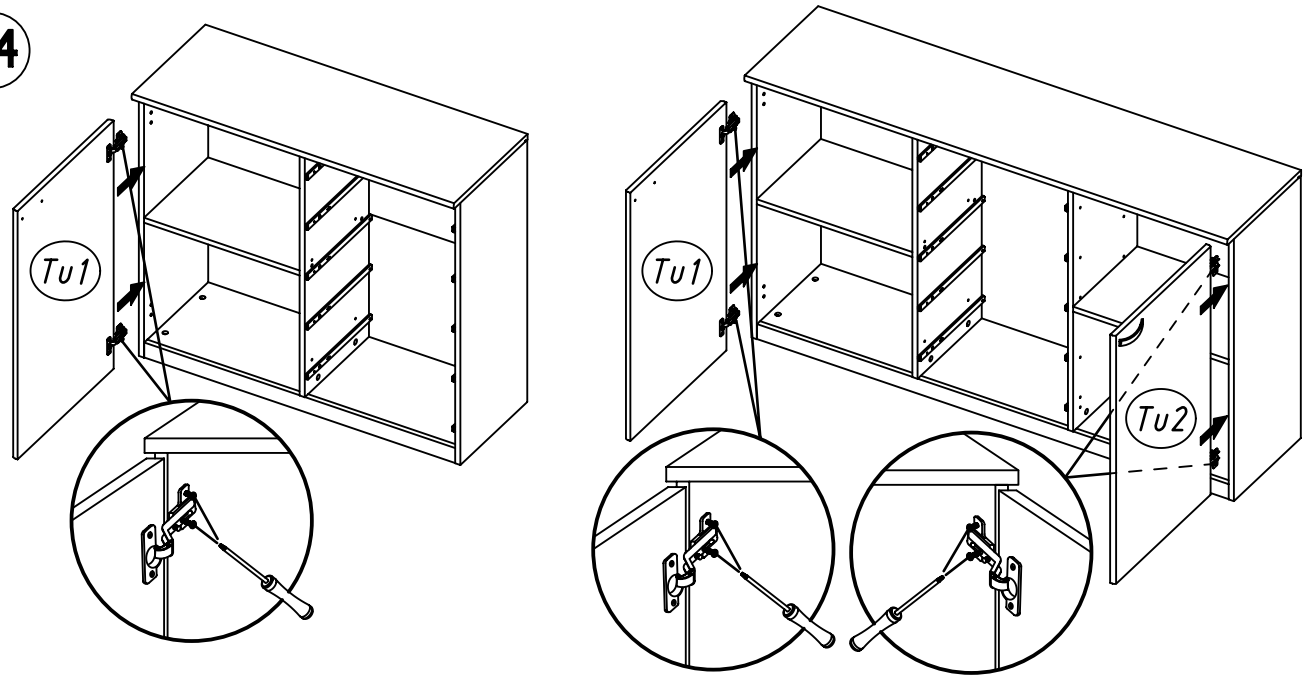

26

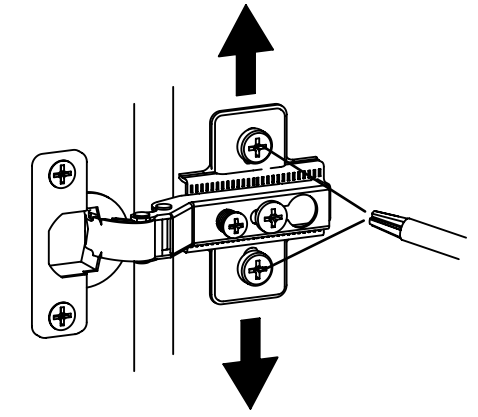
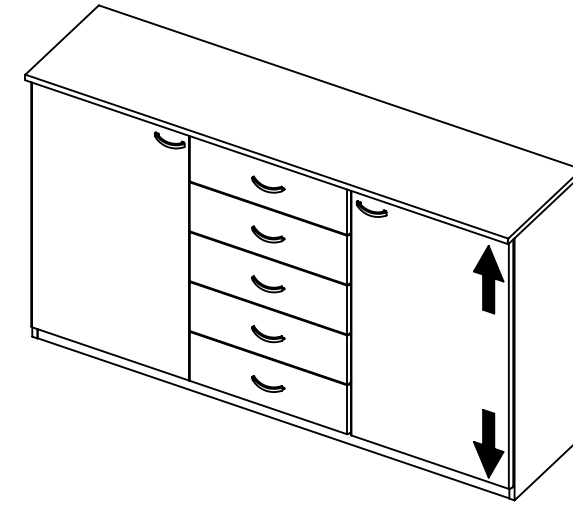

25

568

Typ II

Typ I

568

Sk

568

Sk

